

By Post

Our Ref : P221002-CNMP-R3.2-V

Date : 15th September 2023

Binnies Hong Kong Limited
43/F, AIA Kowloon Tower,
100 How Ming Street,
Kwun Tong, Kowloon, Hong Kong

Attn: Wilson CK Lam

Agreement No. DHSR/IEC/001

Consultancy Service of Independent Environmental Checker (IEC) for Relocation of Diamond Hill Fresh Water and Salt
Water Service Reservoirs to Caverns under Contract No. 21/WSD/21

Construction Noise Management Plan

Dear Sir,

Pursuant to Condition 2.12 of Environmental Permit (EP) No. EP-602/2021, please note the Construction Noise Management Plan Revision 3.2, dated 14 September 2023 submitted under the EP, certified by the Environmental Team Leader on 15 September 2023, had been reviewed and is hereby verified.

Should you have any query, please feel free to contact the undersigned at 3756 9590 or ivanting@umwelt.consulting.

Your faithfully,

For and on behalf of:

Umwelt Consulting Limited



Ting Po Chung Ivan

Independent Environmental Checker



CHUN WO - SINOHYDRO JV

CONSTRUCTION NOISE MANAGEMENT PLAN (CNMP)

CONTRACT NO. 21/WSD/21

RELOCATION OF DIAMOND HILL FRESH WATER AND
SALT WATER RESERVOIRS TO CAVERNS

Approved by:

Revision : 3.2

Date : 14 Sep 2023

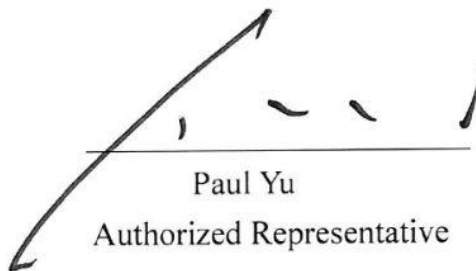

Paul Yu
Authorized Representative

Date: 15 September 2023

Your ref:

Our ref: PL-202309007

Binnies Hong Kong Limited
43/A, AIA Kowloon Tower
100 How Ming Street
Kwun Tong, Kowloon
Hong Kong

Attn.: Mr. Wilson C. K. Lam

Dear Mr. Lam,

Contract No. 21/WSD/21
Relocation of Demand Hill Fresh Water and Salt Water Service Reservoirs to Caverns
Certification of Construction Noise Management Plan

Reference is made to the Construction Noise Management Plan (CNMP) (Revision 3.2, dated 14 September 2023) submitted by the Contractor on 15 September 2023. We are pleased to inform you that we have no adverse comment on the CNMP.

I hereby certify the CNMP for submission under condition 2.12 of Environmental Permit No. EP-602/2021.

Thank you.

Yours sincerely,
For and on behalf of
Acuity Sustainability Consulting Limited



F. C. Tsang
Environmental Team Leader

Encl.

cc. Umwelt Consulting Limited	Mr. Ivan Ting (IEC)	via email
Binnies Hong Kong Limited	Mr. Howie Ho (RE)	via email
Chun Wo – Sinohydro JV	Mr. Elliot Lok (Site agent)	via email

Construction Noise Management Plan (CNMP)

Revision: 3.2

Date: 14 Sep 2023

Checked by:

Position	Signature	Name	Date
Authorized Representative		Paul Yu	14 Sep 2023

Prepared by:

Environmental Officer		Denzel Chan	14 Sep 2023
-----------------------	---	-------------	-------------

CONTENTS

1. Background	2
1.1 Project Description	2
1.2 Requirements for Construction Noise Management Plan (CNMP)	2
2. Description of Construction Works in the Study Area	3
2.1 Noise Sensitive Receivers	3
2.2 Construction Methodology	4
2.3 Updated Preliminary Construction Programme	4
2.4 Updated Powered Mechanical Equipment List	4
3. Noise Assessment and Proposed Mitigation Measures	7
3.1 Assessment Methodology and Assumptions	7
3.2 Proposed Mitigation Strategy and Noise Assessment Results	7
3.3 Good Site Management Practices	12
4. Monitoring and Audit Requirement	13
5. Conclusion	13

LIST OF APPENDICES

Appendix A	Layout Plan of the Works Area showing the NSRs.
Appendix B	Updated Preliminary Construction Programme
Appendix C	Detailed Construction Noise Assessment
Appendix D	Details of Acoustic Noise Barriers
Appendix E	Implementation Schedule of Proposed Mitigation Measures
Appendix F	Concrete Lorry Mixer Sound Power Level Measurement Report
Appendix G	Relevant School Examination Calendar

1. Background

1.1 Project Description

Relocation of Diamond Hill Fresh Water and Salt Water Service Reservoirs to Caverns Environmental Impact Assessment Report (Register No.: AEIAR-232/2021) was approved without conditions by Environmental Protection Department (EPD) on 16 November 2021. An Environmental Permit (EP-602/2021) was issued on 14 December 2021.

Chun Wo – Sinohydro JV (CWSJV) was commissioned by Water Supplies Department as the appointed main contractor for Contract No. 21/WSD/21 Relocation of Diamond Hill Fresh Water and Salt Water Service Reservoirs to Caverns.

The Works to be executed under this Contract included, but not exclusively, the following items:

- (i) Construction of the relocated Diamond Hill Fresh Water and Salt Water Service Reservoirs (DHSRs) and associated pumping stations and water main laying works;
- (ii) Construction of tunnels, adits, ventilation system and caverns for accommodating the relocated DHSRs and the associated facilities;
- (iii) Construction of a 2-storey Portal Ancillary Building; and
- (iv) Other associated works that are incidental to and necessary for the completion of the Project.

A Site Layout showing the site boundary is shown in Appendix A.

1.2 Requirements for Construction Noise Management Plan (CNMP)

According to the condition 2.12 of the EP-602/2021, the Permit Holder shall, no later than 1 month before the commencement of construction of the Project or otherwise approved by the Director, deposit with the Director 3 hard copies and 1 electronic copy of a Construction Noise Management Plan (CNMP).

The CNMP shall include:

- Layout plan(s) detailing the locations and arrangements of the noise mitigation measures, including but not limited to the use of movable noise barriers, enclosures and quality powered mechanical equipment.
- An implementation schedule in table form to clearly list out the mitigation measures to be implemented, and the implementation party, location, timing, and environmental performance required for implementation of the mitigation measures.

Before submission to the Director, the CNMP shall be certified by the ET and verified by the IEC as conforming to the relevant information and recommendations contained in the EIA Report (Register No. AEIAR-232/2021).

If there is any change to the construction noise mitigation measures and/or plant inventory recommended in the deposited CNMP, the Permit Holder shall, no later than 1 month before the implementation of any such change, deposit with the Director 3 hard copies and 1 electronic copy of an updated CNMP. The CNMP and updated CNMP shall be certified by the ET Leader and verified by the IEC as conforming to the relevant information and recommendations of the EIA Report (Register N0. AEIAR-232/2021). All mitigation measures recommended and requirements specified in the CNMP and the updated CNMP shall be fully implemented.

2. Description of Construction Works in the Study Area

2.1 Noise Sensitive Receivers

The list of NSRs is shown in Table 2.1. The layout plan of the works area showing the NSRs is provided in Appendix A.

Table 2.1 List of Noise Sensitive Receivers (NSRs)

NSR	Description	EIA-TM Noise Criteria, dB(A) [1]
NSR 1	Block B, Peninsula Heights	75
NSR 2	Block 1, Meridian Hill	75
NSR 3	Chun Sing House, Tin Ma Court	75
NSR 4	Chun Wai House, Tin Ma Court	75
NSR 5	Grace Methodist Church Kindergarten	70/ (65)
NSR 6	Wang King House, Tin Wang Court	75
NSR 7	Block 6, Tsui Chuk Garden	75
NSR 8	Baptist Rainbow Primary School	70/ (65)
NSR 9	Pang Ching Court	75
NSR 10	Chung Yuen House, Chuk Yuen North Estate	75
NSR 11	Wah Yuen House, Chuk Yuen South Estate	75
NSR 12	Mui Yuen House, Chuk Yuen North Estate	75
NSR 13	Our Lady of Maryknoll Hospital	75
NSR 14	Our Lady's College	70/ (65)
NSR 15	Evangel Children's Home	75
NSR 16	Wing Shing House	75
NSR 17	Ying Fuk Court	75
NSR 18	Diamond Hill Kwong Yum Home for the Aged	75
NSR 19	St. Bonaventure College and High School	70/ (65)
NSR 20	Wu York Yu Health Centre	75
NSR 21	Twghs Wong Tai Sin Hospital	75

NSR 22	Ho Lap Primary School	70/ (65)
NSR 23	Lok Shing House, Tsz Lok Estate	75
NSR 24	Fat Chong Temple	75
NSR 25	Wo Tin House	75
NSR 26	CCC Kei Tsz Primary School	70/ (65)
NSR P1	Sheung Fung Street Customs Staff Quarters	75

Notes: [1] Values in parentheses indicate the noise criterion during examination period of educational institution

2.2 Construction Methodology

The proposed construction methodology is generally following that presented in Section 4.6 of the approved EIA Report (Register No. AEIAR-232/2021).

A breakdown of the major construction activities in sequence to be carried out within the contract are provided in Appendix B.

2.3 Updated Preliminary Construction Programme

Upon reviewing the concurrent projects close to the Project, there is no additional potential concurrent projects which would have cumulative construction noise impacts on the NSRs during the construction phase. The updated preliminary construction programme is provided in Appendix B.

2.4 Updated Powered Mechanical Equipment List

The updated Powered Mechanical Equipment (PME) list for the construction works is provided in Table 2.2. The Sound Power Levels (SWL) for the PMEs have been adopted from EPD's Technical Memorandum on Noise from Construction Work Other than Percussive Piling (GW-TM), list of SWLs of other commonly used PME or British Standard 5228 - Part 1:2009 Code of Practice for Noise and Vibration Control on Construction and Open Sites. It should be noted that the PMEs proposed are commonly available in Hong Kong market. The PMEs to be adopted for individual construction activities for this contract are provided in Appendix C.

If the exact model specified in the references of the listed quiet PME are not available during the construction period, the model with SWL not higher than the listed SWL shall be adopted.

Table 2.2: List of Updated Powered Mechanical Equipment (PME)

PME Description	Other Ref. (a) / QPME ID Code (b) / TM Ref. (c)	Unit Sound Power Level, SWL dB(A)
Air Compressor with QPME label showing a sound power level \leq 98dB(A)	EPD-12829 Brand: AIRMAN Model: PDS390S-5C1	98
Breaker, excavator mounted (hydraulic)	Ref: Sandhurst - XT-200	110
Excavator/loader, wheeled/tracked with QPME label showing a sound power level \leq 95dB(A)	EPD-12806 Brand: KOBELCO Model: SK225SR	95
Generator, silenced, 75dB(A) at 7m with QPME label showing a sound power level \leq 93dB(A)	EPD-13131 Brand: DENYO Model: DCA-220LSIE	93
Concrete lorry mixer	[d]	103
Concrete pump, stationary/lorry mounted	CNP 047	109
Poker, vibratory, Hand-held (electric)	[e]	102
Crane, mobile with QPME label showing a sound power level \leq 93dB(A)	EPD-08588 Brand: Maeda Model: CC423S-1	93
Dump truck, 5.5 tonne < gross vehicle weight \leq 38 tonne	[a]	105
Piling, vibrating hammer	[a]	115
Rock drill, crawler mounted (hydraulic)	CNP 182	123
Water pump (electric)	CNP 281	88
Ventilation fan	CNP 241	108
Conveyor Belt	CNP 041	90
Crusher	[f]	118
Breaker, handheld, mass > 10kg and < 20kg with QPME label showing a sound power level \leq 103dB(A)	EPD-07425 Brand: MAKITA Model: HM1317C	103
Saw, circular, wood	CNP 201	108
Bar bender and cutter (electric)	CNP 021	90
Lorry, with crane/grab, 5.5 tonne < gross vehicle weight \leq 38 tonne	[a]	105
Asphalt paver with QPME label showing a sound power level \leq 104 dB(A)	EPD-12785 Brand: JOSEPH VOEGELE AG /	104

PME Description	Other Ref. (a) / QPME ID Code (b) / TM Ref. (c)	Unit Sound Power Level, SWL dB(A)
	VOEGELE Model: SUPER 1603-3	
Paint line marker	CNP 161	90
Road roller with QPME label showing a sound power level <= 101 dB(A)	EPD-12035 Brand: AMMANN Model: ARX40-2	101
Air blower (electric)	[a]	95
Winch (electric)	CNP 262	95
Hand-held Percussive Breaker with QPME label showing a sound power level <= 99dB(A)	EPD-08782 Brand: Hilti Model: TE 1000-AVR	99
Crawler crane with QPME label showing a sound power level <= 108 dB(A)	EPD-12661 Brand: SANY Model: SCC2500A	108

Notes:

- (a) Sound power levels of other commonly used PME
http://www.epd.gov.hk/epd/sites/default/files/epd/english/application_for_licences/guidance/files/OtherSWLe.pdf
- (b) QPME ID Code refer to Quiet Powered Mechanical Equipment from EPD’s website
http://www.epd.gov.hk/cgi-bin/npg/qpme/search_gen.pl?lang=eng
- (c) Reference for Sandhurst - XT-200 is made from EIA-235/2015 - Development of Anderson Road Quarry Site
- (d) Sound Power Level Measurement Report – Showed in Appendix F.
- (e) Reference is made from EIA-235/2015 - Development of Anderson Road Quarry Site
- (f) Reference is made from AEIAR-126/2008 - West Island Line

3. Noise Assessment and Proposed Mitigation Measures

3.1 Assessment Methodology and Assumptions

The construction noise assessment has been carried out in accordance with the methodology used in the approved EIA Report (Register No. AEIAR-232/2021). The percentage on-time for each PME has been estimated individually for each construction activity to ensure practicality.

All mitigation measures and their effectiveness proposed in the EIA Report (Register No. AEIAR-232/2013) including the use of temporary movable noise barrier and enclosure (with sufficient ventilation) for relatively static plant, acoustic mat and quiet plant have been considered in this CNMP. The use of quiet plant associated with construction work is prescribed in British Standard "Code of practice for noise and vibration control on construction and open sites, BS5228" which contains the SWLs for specific quiet PME.

School calendar for NSR 14 and NSR 19 have been collected for examination period. For worst case scenario, the noise mitigation criteria for the NSRs were set to 65dB(A) for all months. The school calendar of the schools has been given in Appendix G.

3.2 Proposed Mitigation Strategy and Noise Assessment Results

The mitigation measures proposed in the approved EIA report (Register No. AEIAR-232/2013) have been adopted.

To minimise the potential construction noise impacts of the watermain laying work, the pipe section to be constructed by open cut method is limited in a length of no more than 30 m at any one time when works are in close proximity to NSRs. Each work front along the proposed watermain laying should be separated by a clearance distance of at least 60 m.

The use of quiet PME is considered to be a practicable means to mitigate the construction noise impact. Quiet plant is defined as a PME having actual SWL lower than the value specified in the GW-TM.

Movable temporary noise barriers that can be located close to noisy plant and be moved concurrently with the plant along a worksite can be very effective for screening noise from NSRs. A typical design which has been used locally is a wooden framed barrier with a small-cantilevered on a skid footing with 25mm thick internal sound absorptive lining. This measure is particularly effective for low level zone of NSRs. A cantilevered top cover would be required to achieve screening benefits at upper floors of NSRs. Movable barriers will be used for some PME (e.g. asphalt paver, excavator etc). It is anticipated that suitably designed barriers could achieve at least 5 -10dB(A) reduction. For a conservative assessment, only a reduction of 5dB(A) is assumed.

The use of enclosure (The sheet material mass of the noise enclosure should be at least 10 kg/m² and sound-absorbent lining inside the enclosure should be at least 25 mm thick) has been considered to shelter relatively stationary plant including air compressor, generator. The enclosure barriers can provide about 10dB(A) noise reduction. CWSJV shall ensure the practicability to block the line-of-sight for nearby NSRs during the usage of noise barriers.

Proprietary Noise Barriers will be used for mainlaying work for further screening noise from concerned NSRs and could achieve an insertion loss of 22 dB(A). Consider the height of the proprietary noise barriers is 7m, when deployed at work sites including Lung Fung Street, this proprietary noise barriers will be capable to shield the PME from the NSR completely. As such a 10dB(A) reduction is assumed. The catalogue of the proprietary noise barriers is given in Appendix D. The illustration showing the noise barrier during works is also shown in Appendix D.

Blast door will be installed for blockage of noise from tunnel. This blast door served as noise enclosure and is lined with absorptive materials shall be provided at the tunnel portal to mitigate the noise from tunnel/cavern construction. This noise enclosure at the portal will be designed by consultant and the relevant details be updated in the CNMP shortly. The enclosure is a gap free enclosure with acoustic doors for vehicular access purpose. The acoustic doors shall remain closed throughout the construction period. The sheet material mass of the noise enclosure should be at least 10 kg/m² and sound-absorbent lining inside the enclosure should be at least 25 mm thick. The construction activities to be carried out in underground / cavern and there is no direct line of sight from the NSR to works inside the tunnel. This blast door will adopt 20dB(A) reduction screening effect.

Noise barrier /enclosure/ proprietary Noise Barriers should be inspected and maintained regularly. CWSJV should design and provide details of the temporary noise barriers, noise enclosure and blast door to the Engineer for approval.

All mitigation measures recommended, and requirements specified in the CNMP and the updated CNMP shall be fully implemented.

Mitigated Scenario 1 – Adoption of Quiet PME & Temporary Noise Barriers/Enclosures

The mitigated noise levels at the representative NSRs for mitigated scenario 1 were calculated and the results are summarised in Table 3.1. with details of the calculations given in The detailed calculations is given in Appendix C. With the implementation of the mitigated scenario 1, noise exceedances at NSR 5, NSR 14 and NSR 19 are predicted.

Table 3-1 Predicted Construction Noise Levels (Mitigated Scenario 1)

NSR	Description	Maximum Predicted Noise Level, dB(A)	EIA-TM Noise Criteria, dB(A) [1]	Compliance
NSR 1	Block B, Peninsula Heights	71	75	Yes
NSR 2	Block 1, Meridian Hill	72	75	Yes
NSR 3	Chun Sing House, Tin Ma Court	66	75	Yes
NSR 4	Chun Wai House, Tin Ma Court	66	75	Yes
NSR 5	Grace Methodist Church Kindergarten	<u>67</u>	70/ (65)	<u>No</u>
NSR 6	Wang King House, Tin Wang Court	64	75	Yes
NSR 7	Block 6, Tsui Chuk Garden	62	75	Yes
NSR 8	Baptist Rainbow Primary School	56	70/ (65)	Yes
NSR 9	Pang Ching Court	57	75	Yes
NSR 10	Chung Yuen House, Chuk Yuen North Estate	60	75	Yes
NSR 11	Wah Yuen House, Chuk Yuen South Estate	61	75	Yes
NSR 12	Mui Yuen House, Chuk Yuen North Estate	56	75	Yes
NSR 13	Our Lady of Maryknoll Hospital	72	75	Yes
NSR 14	Our Lady's College	<u>70</u>	70/ (65)	<u>No</u>
NSR 15	Evangel Children's Home	66	75	Yes
NSR 16	Wing Shing House	66	75	Yes
NSR 17	Ying Fuk Court	51	75	Yes
NSR 18	Diamond Hill Kwong Yum Home for the Aged	62	75	Yes
NSR 19	St. Bonaventure College and High School	<u>69</u>	70/ (65)	<u>No</u>
NSR 20	Wu York Yu Health Centre	68	75	Yes
NSR 21	Twghs Wong Tai Sin Hospital	55	75	Yes
NSR 22	Ho Lap Primary School	57	70/ (65)	Yes
NSR 23	Lok Shing House, Tsz Lok Estate	58	75	Yes
NSR 24	Fat Chong Temple	51	75	Yes
NSR 25	Wo Tin House	63	75	Yes
NSR 26	CCC Kei Tsz Primary School	56	70/ (65)	Yes

NSR	Description	Maximum Predicted Noise Level, dB(A)	EIA-TM Noise Criteria, dB(A) [1]	Compliance
NSR P1	Sheung Fung Street Customs Staff Quarters	67	75	Yes

Notes: [1] Values in parentheses indicate the noise criterion during examination period of educational institution

Mitigated Scenario 2 – Additional Mitigation Measures.

During examination period, Fresh Water / Salt Water Main laying (Reinstatement Works) will be carried out 20m from the school site boundary. The reduced construction noise levels at these NSRs during normal school days / examination period have been quantitatively assessed and the calculation.

The mitigated noise levels at the representative NSRs were calculated and the results are summarised in Table 3-2 with details of the calculations given in Appendix C. With the adoption of recommended mitigation measures, the construction noise level at the representative NSRs will comply with the required noise criteria.

Table 3-2 Predicted Construction Noise Levels for NSR 5, NSR14 and NSR19 (Mitigated Scenario 2)

NSR	Description	Maximum Predicted Noise Level, dB(A)	EIA-TM Noise Criteria, dB(A) [1]	Compliance
NSR 5	Grace Methodist Church Kindergarten	67/65*	70/ (65)	Yes
NSR 14	Our Lady's College	70/59*	70/ (65)	Yes
NSR 19	St. Bonaventure College and High School	69/59*	70/ (65)	Yes

Notes:

[1] Values in parentheses indicate the noise criterion during examination period of educational institution.

* Implementation of mitigated scenario 1 and Fresh Water / Salt Water Main laying (Reinstatement Works) will be carried out 20m from the school site boundary during examination period. From NSR 14 and NSR 19 examination schedule enclosure are shown in Appendix G. Kindergarten no exam.

The predicted noise levels at identified NSRs after implementation of mitigation measures, including quiet plants, noise enclosure/shed, movable barriers and enclosure are shown in Appendix C and summarised in Table 3.1 and Table 3.2. Summary of PME with proposed mitigation measures are shown in table 3.3.

Table 3-3 Summary of PME with proposed mitigation measures

Construction Activities	PME	Proposed Mitigation Measures	Noise Reduction, dB(A)
<p><u>1.Site Mobilization:</u> -Excavation Cavern -Formation of works site - Mobilization of construction plants and materials</p> <p><u>2.Cavern and Tunnel Construction:</u> -Open-cut Construction of Tunnel and Tunnel Portal (Group 1) -Open-cut Construction of Tunnel and Tunnel Portal (Group 2)</p> <p><u>3.Structural Works:</u> - Ancillary Buildings at Tunnel Portal – Excavation, Foundation, Structural Works</p> <p><u>4. Main laying</u> -Fresh Water / Salt Water Main laying - Surface Breaking and Excavation & Pipe laying -Fresh Water / Salt Water Main laying – Reinstatement</p> <p><u>5. E&M Installation</u> -E&M Installation for Ancillary Buildings</p> <p><u>6. Other Associated Works</u> -Slope, Landscaping Works, and Reinstatement for Access Tunnel Portal</p>	Air blower (electric)	Movable barrier	5
	Bar bender and cutter (electric)		
	Breaker, excavator mounted (hydraulic)		
	Breaker, handheld, mass > 10kg and < 20kg with QPME label showing a sound power level <= 103dB(A)		
	Concrete lorry mixer		
	Concrete pump, stationary/lorry mounted		
	Dump truck, 5.5 tonne < gross vehicle weight ≤ 38 tonne		
	Excavator/loader, wheeled/tracked with QPME label showing a sound power level <= 95dB(A)		
	Hand-held Percussive Breaker with QPME label showing a sound power level <= 99dB(A)		
	Lorry, with crane/grab, 5.5 tonne < gross vehicle weight ≤ 38 tonne		
	Paint line marker		
	Piling, vibrating hammer		
	Poker, vibratory, Hand-held (electric)		
	Saw, circular, wood		
Water pump (electric)			
Winch (electric)			

Construction Activities	PME	Proposed Mitigation Measures	Noise Reduction, dB(A)
<p><u>4. Main laying:</u> -Fresh Water / Salt Water Main laying – Reinstatement</p>	Asphalt paver with QPME label showing a sound power level ≤ 104 dB(A)	Propriety Noise Barriers	10
	Concrete lorry mixer		
	Dump truck, 5.5 tonne < gross vehicle weight ≤ 38 tonne		
	Poker, vibratory, hand-held (electric)		
	Road roller with QPME label showing a sound power level ≤ 101 dB(A)		
<p><u>1.Site Mobilization:</u> -Excavation Cavern -Formation of works site - Mobilization of construction plants and materials</p> <p><u>2.Cavern and Tunnel Construction:</u> -Open-cut Construction of Tunnel and Tunnel Portal (Group 1) -Stone Crushing</p> <p><u>3.Structural Works:</u> - Ancillary Buildings at Tunnel Portal – Excavation, Foundation, Structural Works</p> <p><u>4. Main laying</u> -Fresh Water / Salt Water Main laying - Surface Breaking -Fresh Water / Salt Water Main laying – Reinstatement</p>	Air Compressor, air flow > 10m ³ /min and < 30m ³ /min with QPME label showing a sound power level ≤ 98 dB(A)	Noise enclosure	10
	Crusher		
	Generator, silenced, 75 dB(A) at 7 m with QPME label showing a sound power level ≤ 93 dB(A)		

Construction Activities	PME	Proposed Mitigation Measures	Noise Reduction, dB(A)
<p><u>2.Cavern and Tunnel Construction:</u> -Excavation of Access Tunnel -Excavation of Cavern</p> <p><u>3.Structural Works:</u> -Structural Works for Relocated DHSRs and Pumping Stations</p> <p><u>5. E&M Installation</u> -E&M Installation for Relocated DHSRs and Pumping Stations</p>	Bar bender and cutter (electric)	Acoustic doors at tunnel portal	20
	Breaker, excavator mounted (hydraulic)		
	Concrete lorry mixer		
	Concrete pump, stationary/lorry mounted		
	Conveyor Belt		
	Crane, mobile with QPME label showing a sound power level $\leq 93\text{dB(A)}$		
	Dump truck, 5.5 tonne < gross vehicle weight ≤ 38 tonne		
	Generator, silenced, 75 dB(A) at 7 m		
	Lorry, with crane/grab, 5.5 tonne < gross vehicle weight ≤ 38 tonne		
	Poker, vibratory, Hand-held (electric)		
	Rock drill, crawler mounted (hydraulic)		
	Saw, circular, wood		
	Ventilation fan		
	Water pump (electric)		

3.3 Good Site Management Practices

CWSJV shall implement the following good site management practices to reduce the potential noise impact of the construction activities on near NSRs,

1. Only well-maintained plant should be operated on-site, and plant will be serviced regularly during the construction phase;

2. Silencers or mufflers on construction equipment should be utilized and should be properly maintained during the construction phase;
3. Mobile plant, if any, should be sited away from NSRs;
4. Machines and plant (such as trucks) that may be in intermittent use should be shut down between work periods or will be throttled down to a minimum;
5. Plant known to emit noise strongly in one direction should be orientated so that the noise is directed away from the nearby NSRs;
6. Material stockpiles and other structures should be effectively utilized in screening noise from on-site construction activities;
7. The contractor should devise, arrange methods of working and carrying out the works in such manner as to minimise noise impacts on the surrounding environment, and should provide experience personnel with suitable training to ensure that all these measures are implemented properly; and;
8. The contractor should minimise construction noise exposure to the school (especially during examination periods) as much as possible. The contractor should liaise with the school and Examination Authority to ascertain the exact dates and times of all examination periods during the course of the contract and to avoid noisy activities during these periods.

4. Monitoring and Audit Requirement

Noise monitoring and weekly site audit are proposed to be carried out during construction phase. The mitigation measures and noise control design will be implemented by the frontline staff of the contractor, supervised by the Environmental Officer/ Site Engineer and checked by the ET, IEC and RE during routine site inspection under the EM&A programme.

Site records, including photos and measurement reports, for substantiating proper implementation of the Plan shall be well kept by the Contractor on site for review/checking by ET/IEC/EPD at any time. The implementation schedule of proposed mitigation measures is showed in Appendix E.

The public are welcome to contact us through the hotline (9233 9816). We aim to handle and provide immediate response to the enquiries and complaints on environmental issues from the public.

5. Conclusion

The use of powered mechanical equipment during the construction phase of the Project is expected to create noise impact to the nearby NSRs. Assessment indicates that the construction noise impact can be mitigated to the criteria in the EIAO-TM by use of quiet construction equipment, erecting noise barriers / enclosures and use of quieter construction method

Contract No. 21/WSD/21

Relocation of Diamond Hill Fresh Water and Salt Water Service Reservoirs to Caverns

restrictions on construction works near schools. With the implementation of the recommended mitigation measures, no exceedance of the daytime construction noise criteria is expected.

Contract No. 21/WSD/21

Relocation of Diamond Hill Fresh Water and Salt Water Reservoirs to Caverns

Appendix A – Layout Plan of the Works Area showing the NSRs



- Legend**
- Representative Noise Sensitive Receivers
 - ▭ Study Area (300m)
 - ▨ Works Area A
 - ▨ Works Area B
 - ▨ Works Area C
 - ▨ Works Area D
 - ▨ Works Area E
 - ▨ Works Area F

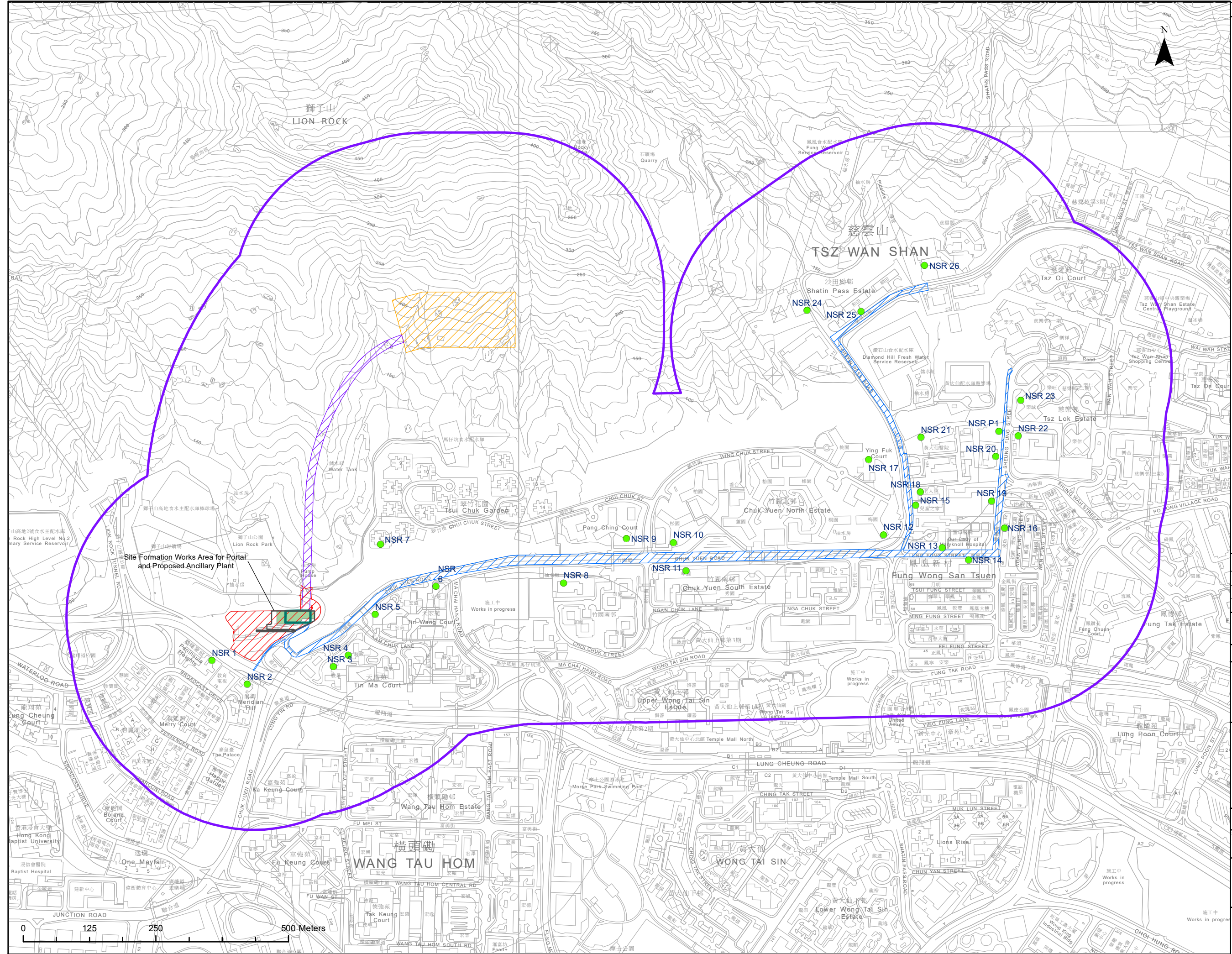

Revision	Description			
	Designed	Reviewed	Drawn	Checked
Initial	PSY	ET	PSY	ET
Date	6/21	6/21	6/21	6/21

Approved

Agreement No. **CE 15/2018 (WS)**

Project Title
Relocation of Diamond Hill Fresh Water and Salt Water Service Reservoirs to Caverns – Investigation, Design and Construction

Figure Title
Locations of Works Area

Drawing No. **Appendix 4C-2** Revision **-**

Scale **A3: 1:6,500**

Client **水務署 Water Supplies Department**

Consultant **binnies**



Contract No. 21/WSD/21

Relocation of Diamond Hill Fresh Water and Salt Water Reservoirs to Caverns

Appendix B – Updated Preliminary Construction Programme

Contract No. 21/WSD/21

Relocation of Diamond Hill Fresh Water and Salt Water Reservoirs to Caverns

Appendix C – Detailed Construction Noise Assessment

Construction Plant Inventory (Mitigated Scenario 1)

Works ID	Activities	Plant	TM Ref. / Other Ref.	Unit SWL, dB(A)	No. of PME	On-time %	Type of Noise Control	Noise reduction, dB(A)	SWL, dB(A)	Total SWL, dB(A)	
	General										
1-1	Site Mobilization - Excavation	Air Compressor, air flow > 10m ³ /min and < 30m ³ /min	EPD-12829 Brand: AIRMAN Model : PDS390S-5C1	98	1	100%	Enclosure	-10	88	102	
		Breaker, excavator mounted (hydraulic)	(Ref: Sandhurst - XT-200) ^[4]	110	1	50%	Barrier	-5	102		
		Excavator/loader, wheeled/tracked	EPD-12806 Brand: KOBELCO Model : SK225SR	95	1	100%	Barrier	-5	90		
		Generator, silenced, 75dB(A) at 7m	EPD-13131 Brand :DENYO Model : DCA-220LSIE	93	1	50%	Enclosure	-10	80		
	Site Mobilization - Formation of works site	Concrete lorry mixer	[5]	103	1	40%	Barrier	-5	94	97	
		Poker, vibratory, Hand-held (electric)	[6]	102	1	40%	Barrier	-5	93		
		Generator, silenced, 75dB(A) at 7m	EPD-13131 Brand :DENYO Model : DCA-220LSIE	93	1	100%	Enclosure	-10	83		
	Site Mobilization - Mobilization of construction plants and materials	Crane, mobile	EPD-08588 Brand : Maeda Model : CC423S-1	93	1	45%				90	98
		Dump truck, 5.5 tonne < gross vehicle weight ≤ 38 tonne	[2]	105	1	50%	Barrier	-5	97		
		Generator, silenced, 75dB(A) at 7m	EPD-13131 Brand :DENYO Model : DCA-220LSIE	93	1	100%	Enclosure	-10	83		

Works ID	Activities	Plant	TM Ref./ Other Ref.	Unit SWL, dB(A)	No. of PME	On- time %	Type of Noise Control	Noise reduction, dB(A)	SWL, dB(A)	Total SWL, dB(A)
	Cavern and Tunnel Construction									
2-1	Open-cut Construction of Tunnel and Tunnel Portal	Excavator/loader, wheeled/tracked	EPD-12806 Brand: KOBELCO Model : SK225SR	95	2	70%	Barrier	-5	91	107
		Dump truck, 5.5 tonne < gross vehicle weight ≤ 38 tonne	[2]	105	1	70%	Barrier	-5	98	
		Air Compressor, air flow > 10m ³ /min and < 30m ³ /min	EPD-12829 Brand: AIRMAN Model : PDS390S-5C1	98	2	100%	Enclosure	-10	91	
		Piling, vibrating hammer	[2]	115	1	40%	Barrier	-5	106	
	Open-cut Construction of Tunnel and Tunnel Portal (Group 2)	Crawler crane	EPD-12661 Brand: SANY Model : SCC2500A	108	1	50%			105	107
		Poker, vibratory, Hand-held (electric)	[6]	102	1	50%	Barrier	-5	94	
		Saw, circular, wood	CNP 201	108	1	50%	Barrier	-5	100	
		Bar bender and cutter (electric)	CNP 021	90	2	50%	Barrier	-5	85	
		Water pump (electric)	CNP 281	88	2	80%	Barrier	-5	85	
		Concrete pump, stationary/lorry mounted	CNP 047	109	1	30%	Barrier	-5	99	
	Concrete lorry mixer	[5]	103	1	50%	Barrier	-5	95		
2-2	Excavation of Access Tunnel	Rock drill, crawler mounted (hydraulic)	CNP 182	123	1	75%	Inside Cavern	-20	102	103
		Breaker, excavator mounted (hydraulic)	(Ref: Sandhurst - XT-200) ^[4]	110	1	80%	Inside Cavern	-20	89	
		Water pump (electric)	CNP 281	88	2	80%	Inside Cavern	-20	70	
		Concrete pump, stationary/lorry mounted	CNP 047	109	1	60%	Inside Cavern	-20	87	
		Concrete lorry mixer	[5]	103	1	60%	Inside Cavern	-20	81	
		Dump truck, 5.5 tonne < gross vehicle weight ≤ 38 tonne	[2]	105	1	70%	Inside Cavern	-20	83	
		Ventilation fan	CNP 241	108	2	100%	Inside Cavern	-20	91	
		Conveyor Belt	CNP 041	90	1	100%	Inside Cavern	-20	70	
2-3	Excavation of Cavern	Rock drill, crawler mounted (hydraulic)	CNP 182	123	1	75%	Inside Cavern	-20	102	103
		Breaker, excavator mounted (hydraulic)	(Ref: Sandhurst - XT-200) ^[4]	110	1	80%	Inside Cavern	-20	89	
		Water pump (electric)	CNP 281	88	2	80%	Inside Cavern	-20	70	
		Concrete pump, stationary/lorry mounted	CNP 047	109	1	60%	Inside Cavern	-20	87	
		Concrete lorry mixer	[5]	103	1	60%	Inside Cavern	-20	81	
		Dump truck, 5.5 tonne < gross vehicle weight ≤ 38 tonne	[2]	105	1	70%	Inside Cavern	-20	83	
		Ventilation fan	CNP 241	108	2	100%	Inside Cavern	-20	91	
		Conveyor Belt	CNP 041	90	1	100%	Inside Cavern	-20	70	
2-4	Stone Crushing	Crusher	[7]	118	1	50%	Enclosure	-10	105	105

Works ID	Activities	Plant	TM Ref./ Other Ref.	Unit SWL, dB(A)	No. of PME	On- time %	Type of Noise Control	Noise reduction, dB(A)	SWL, dB(A)	Total SWL, dB(A)	
	Structural Works										
3-1	Ancillary Buildings at Tunnel Portal - Excavation	Air Compressor, air flow > 10m ³ /min and < 30m ³ /min	EPD-12829 Brand: AIRMAN Model : PDS390S-5C1	98	1	100%	Enclosure	-10	88	102	
		Breaker, hand held, mass > 10kg and < 20kg	EPD-07425 Brand : MAKITA Model : HM1317C	103	1	50%	Barrier	-5	95		
		Excavator/loader, wheeled/tracked	EPD-12806 Brand: KOBELCO Model : SK225SR	95	2	70%	Barrier	-5	91		
		Dump truck, 5.5 tonne < gross vehicle weight ≤ 38 tonne	[2]	105	2	50%	Barrier	-5	100		
		Generator, silenced, 75dB(A) at 7m	EPD-13131 Brand :DENYO Model : DCA-220LSIE	93	1	100%	Enclosure	-10	83		
	Ancillary Buildings at Tunnel Portal - Foundation	Concrete lorry mixer	[5]	103	2	50%	Barrier	-5	98	106	
		Concrete pump, stationary/lorry mounted	CNP 047	109	1	50%	Barrier	-5	101		
		Poker, vibratory, Hand-held (electric)	[6]	102	2	50%	Barrier	-5	97		
		Saw, circular, wood	CNP 201	108	2	60%	Barrier	-5	104		
		Bar bender and cutter (electric)	CNP 021	90	2	60%	Barrier	-5	86		
		Crane, mobile	EPD-08588 Brand : Maeda Model : CC423S-1	93	1	40%			89		
		Dump truck, 5.5 tonne < gross vehicle weight ≤ 38 tonne	[2]	105	1	50%	Barrier	-5	97		
	Generator, silenced, 75dB(A) at 7m	EPD-13131 Brand :DENYO Model : DCA-220LSIE	93	1	100%	Enclosure	-10	83			
Ancillary Buildings at Tunnel Portal - Structural Works	Concrete pump, stationary/lorry mounted	CNP 047	109	1	50%	Barrier	-5	101	106		
	Concrete lorry mixer	[5]	103	1	80%	Barrier	-5	97			
	Poker, vibratory, Hand-held (electric)	[6]	102	2	80%	Barrier	-5	99			
	Saw, circular, wood	CNP 201	108	1	60%	Barrier	-5	101			
	Bar bender and cutter (electric)	CNP 021	90	1	70%	Barrier	-5	83			
	Tower crane	CNP 049	95	1	60%			93			
	Generator, silenced, 75dB(A) at 7m	EPD-13131 Brand :DENYO Model : DCA-220LSIE	93	1	100%	Enclosure	-10	83			
3-2	Structural Works for Relocated DHSRs and Pumping Stations	Crane, mobile	EPD-08588 Brand : Maeda Model : CC423S-1	93	1	70%	Inside Cavern	-20	71	89	
		Concrete lorry mixer	[5]	103	1	80%	Inside Cavern	-20	82		
		Poker, vibratory, Hand-held (electric)	[6]	102	1	80%	Inside Cavern	-20	81		
		Generator, silenced, 75dB(A) at 7m	EPD-13131 Brand :DENYO Model : DCA-220LSIE	93	1	100%	Inside Cavern	-20	73		
		Saw, circular, wood	CNP 201	108	1	70%	Inside Cavern	-20	86		
Bar bender and cutter (electric)	CNP 021	90	1	70%	Inside Cavern	-20	68				

Works ID	Activities	Plant	TM Ref./ Other Ref.	Unit SWL, dB(A)	No. of PME	On- time %	Type of Noise Control	Noise reduction, dB(A)	SWL, dB(A)	Total SWL, dB(A)
	<u>Mainlaying</u>									
4-1	Fresh Water / Salt Water Mainlaying - Surface Breaking	Hand-held Percussive Breaker	EPD-08782 Brand :Hilti Model : TE 1000-AVR	99	1	30%	Barrier	-5	89	90
		Generator, silenced, 75dB(A) at 7m	EPD-13131 Brand :DENYO Model : DCA-220LSIE	93	1	100%	Enclosure	-10	83	
	Fresh Water / Salt Water Mainlaying - Excavation & Pipe laying	Excavator/loader, wheeled/tracked	EPD-12806 Brand: KOBELCO Model : SK225SR	95	1	50%	Barrier	-5	87	87
	Fresh Water / Salt Water Mainlaying - Reinstatement (Group 1)	Concrete lorry mixer	[5]	103	1	50%	Barrier (Type 2)	-10	90	90
	Fresh Water / Salt Water Mainlaying - Reinstatement (Group 2)	Poker, vibratory, Hand-held (electric) Generator, silenced, 75 dB(A) at 7 m	[6] EPD-13131 Brand :DENYO Model : DCA-220LSIE	102 93	1 1	50% 100%	Barrier (Type 2) Enclosure	-10 -10	89 83	90
	Fresh Water / Salt Water Mainlaying - Reinstatement (Group 3)	Asphalt paver	EPD-12785 Brand :JOSEPH VOEGELE AG / VOEGELE Model : SUPER 1603-3	104	1	40%	Barrier (Type 2)	-10	90	90
	Fresh Water / Salt Water Mainlaying - Reinstatement (Group 4)	Dump truck, 5.5 tonne < gross vehicle weight ≤ 38 tonne	[2]	105	1	30%	Barrier (Type 2)	-10	90	90
	Fresh Water / Salt Water Mainlaying - Reinstatement (Group 5)	Paint line marker	CNP 161	90	1	50%	Barrier	-5	82	82
	Fresh Water / Salt Water Mainlaying - Reinstatement (Group 6)	Road roller	EPD-12035 Brand : AMMANN Model : ARX40-2	101	1	50%	Barrier (Type 2)	-10	88	88
	Fresh Water / Salt Water Mainlaying - Reinstatement (Group 7)	Air blower (electric)	[2]	95	1	50%	Barrier	-5	87	90
		Winch (electric)	CNP 262	95	1	50%	Barrier	-5	87	

Works ID	Activities	Plant	TM Ref. / Other Ref.	Unit SWL, dB(A)	No. of PME	On- time %	Type of Noise Control	Noise reduction, dB(A)	SWL, dB(A)	Total SWL, dB(A)
	<u>E&M Installation</u>									
5-1	E&M Installation for Ancillary Buildings	Lorry, with crane/grab, 5.5 tonne < gross vehicle weight ≤ 38 tonne	[2]	105	1	100%	Barrier	-5	100	102
		Dump truck, 5.5 tonne < gross vehicle weight ≤ 38 tonne	[2]	105	1	50%	Barrier	-5	97	
5-2	E&M Installation for Relocated DHSRs and Pumping Stations	Lorry, with crane/grab, 5.5 tonne < gross vehicle weight ≤ 38 tonne	[2]	105	1	100%	Inside Cavern	-20	85	89
		Ventilation fan	CNP 241	108	1	70%	Inside Cavern	-20	86	
		Generator, silenced, 75 dB(A) at 7 m	EPD-13131 Brand :DENYO Model : DCA-220LSIE	93	1	100%	Inside Cavern	-20	73	

Works ID	Activities	Plant	TM Ref. / Other Ref.	Unit SWL, dB(A)	No. of PME	On- time %	Type of Noise Control	Noise reduction, dB(A)	SWL, dB(A)	Total SWL, dB(A)
	<u>Other Associated Works</u>									
6-1	Slope, Landscaping Works and Reinstatement for Access Tunnel Portal	Lorry, with crane/grab, 5.5 tonne < gross vehicle weight ≤ 38 tonne	[2]	105	1	70%	Barrier	-5	98	98

Notes:

- [1] As only one group of PME would be operated simultaneously under same Works ID, only the activity with the highest total SWL under the same Works ID will be used for the construction noise assessment for each NSR
- [2] Sound power levels of other commonly used PME (http://www.epd.gov.hk/epd/sites/default/files/epd/english/application_for_licences/guidance/files/OtherSWLe.pdf)
- [3] Quality Powered Mechanical Equipment (https://www.epd.gov.hk/cgi-bin/npg/qpme/search_gen.pl?lang=eng&st=sim&valid=Y)
- [4] Reference for Sandhurst - XT-200 is made from EIA-235/2015 - Development of Anderson Road Quarry Site
- [5] Reference for Concrete Lorry Mixer is made from sound power level measurement report
- [6] Reference is made from EIA-235/2015 - Development of Anderson Road Quarry Site
- [7] Reference is made from AEIAR-126/2008 - West Island Line

Summary of Predicted Noise Levels from Construction (Mitigated Scenario 1)

NSR	Description	EIAO-TM Noise Criteria, dB(A)	Max. Predicted CNL, db(A)			
			Low Level	Mid Level	High Level	Overall
NSR 1	Block B, Peninsula Heights	75	71	71	69	71
NSR 2	Block 1, Meridian Hill	75	71	72	71	72
NSR 3	Chun Sing House, Tin Ma Court	75	66	66	64	66
NSR 4	Chun Wai House, Tin Ma Court	75	66	66	64	66
NSR 5	Grace Methodist Church Kindergarten	70/65	67	N/A	N/A	67
NSR 6	Wang King House, Tin Wang Court	75	64	60	59	64
NSR 7	Block 6, Tsui Chuk Garden	75	62	62	56	62
NSR 8	Baptist Rainbow Primary School	70/65	56	56	56	56
NSR 9	Pang Ching Court	75	57	53	52	57
NSR 10	Chung Yuen House, Chuk Yuen North Estate	75	60	53	51	60
NSR 11	Wah Yuen House, Chuk Yuen South Estate	75	61	57	54	61
NSR 12	Mui Yuen House, Chuk Yuen North Estate	75	56	51	48	56
NSR 13	Our Lady of Maryknoll Hospital	75	72	63	59	72
NSR 14	Our Lady's College	70/65	70	68	61	70
NSR 15	Evangel Children's Home	75	66	62	59	66
NSR 16	Wing Shing House	75	66	62	59	66
NSR 17	Ying Fuk Court	75	51	50	48	51
NSR 18	Diamond Hill Kwong Yum Home for the Aged	75	62	61	58	62
NSR 19	St. Bonaventure College and High School	70/65	69	62	57	69
NSR 20	Wu York Yu Health Centre	75	68	65	63	68
NSR 21	Twghs Wong Tai Sin Hospital	75	54	55	54	55
NSR 22	Ho Lap Primary School	70/65	57	57	55	57
NSR 23	Lok Shing House, Tsz Lok Estate	75	58	50	46	58
NSR 24	Fat Chong Temple	75	51	51	51	51
NSR 25	Wo Tin House	75	63	50	47	63
NSR 26	CCC Kei Tsz Primary School	70/65	56	55	53	56
NSR P1	Sheung Fung Street Customs Staff Quarters	75	67	54	49	67

Predicted Noise Level exceeded the corresponding EIAO-TM noise criteria of 75 db(A) for residential / 70 db(A) for school during normal school days

Predicted Noise Level exceeded the corresponding EIAO-TM noise criteria of 65db(A) for school during examination period

Construction Noise Assessment (Mitigated Scenario 1)

NSR 3

Chun Sing House, Tin Ma Court

Representative Floor:		1		mPD Level:		57		(Low Level)		2023												2024												2025												2026												2027											
Activity	Works ID	Works Area	Hor. Dist. m	mPD Level	SWL dB(A)	Distance m	Corr. for Distance dB(A) [1][2]	Corr. for Topo	Corr. for façade dB(A)	4	5	6	7	8	9	10	11	12	1	2	3	4	5	6	7	8	9	10	11	12	1	2	3	4	5	6	7	8	9	10	11	12	1	2	3	4	5	6	7	8	9	10	11	12	1	2	3	4	5	6	7	8	9	10	11	12			
General																																																																					
Site Mobilization																																																																					
Cavern and Tunnel Construction																																																																					
Open-cut Construction of Tunnel and Tunnel Portal																																																																					
Excavation of Access Tunnel																																																																					
Excavation of Cavern																																																																					
Stone Crushing																																																																					
Structural Works																																																																					
Ancillary Buildings at Tunnel Portal																																																																					
Structural Works for Relocated DHSRs and Pumping Stations																																																																					
Mainlaying Works																																																																					
Fresh Water / Salt Water Mainlaying																																																																					
E&M Installation																																																																					
E&M Installation for Ancillary Buildings																																																																					
E&M Installation for Relocated DHSRs and Pumping Stations																																																																					
Other Associated Works																																																																					
Slope, Landscaping Works and Reinstatement for Access Tunnel Portal																																																																					
Predicted Noise Level during Daytime Period, dB(A)																																																																					

Representative Floor:		19		mPD Level:		106		(Mid Level)		2023												2024												2025												2026												2027											
Activity	Works ID	Works Area	Hor. Dist. m	mPD Level	SWL dB(A)	Distance m	Corr. for Distance dB(A) [1][2]	Corr. for Topo	Corr. for façade dB(A)	4	5	6	7	8	9	10	11	12	1	2	3	4	5	6	7	8	9	10	11	12	1	2	3	4	5	6	7	8	9	10	11	12	1	2	3	4	5	6	7	8	9	10	11	12	1	2	3	4	5	6	7	8	9	10	11	12			
General																																																																					
Site Mobilization																																																																					
Cavern and Tunnel Construction																																																																					
Open-cut Construction of Tunnel and Tunnel Portal																																																																					
Excavation of Access Tunnel																																																																					
Excavation of Cavern																																																																					
Stone Crushing																																																																					
Structural Works																																																																					
Ancillary Buildings at Tunnel Portal																																																																					
Structural Works for Relocated DHSRs and Pumping Stations																																																																					
Mainlaying Works																																																																					
Fresh Water / Salt Water Mainlaying																																																																					
E&M Installation																																																																					
E&M Installation for Ancillary Buildings																																																																					
E&M Installation for Relocated DHSRs and Pumping Stations																																																																					
Other Associated Works																																																																					
Slope, Landscaping Works and Reinstatement for Access Tunnel Portal																																																																					
Predicted Noise Level during Daytime Period, dB(A)																																																																					

Representative Floor:		37		mPD Level:		154		(High Level)		2023												2024												2025												2026												2027											
Activity	Works ID	Works Area	Hor. Dist. m	mPD Level	SWL dB(A)	Distance m	Corr. for Distance dB(A) [1][2]	Corr. for Topo	Corr. for façade dB(A)	4	5	6	7	8	9	10	11	12	1	2	3	4	5	6	7	8	9	10	11	12	1	2	3	4	5	6	7	8	9	10	11	12	1	2	3	4	5	6	7	8	9	10	11	12	1	2	3	4	5	6	7	8	9	10	11	12			
General																																																																					
Site Mobilization																																																																					
Cavern and Tunnel Construction																																																																					
Open-cut Construction of Tunnel and Tunnel Portal																																																																					
Excavation of Access Tunnel																																																																					
Excavation of Cavern																																																																					
Stone Crushing																																																																					
Structural Works																																																																					
Ancillary Buildings at Tunnel Portal																																																																					
Structural Works for Relocated DHSRs and Pumping Stations																																																																					
Mainlaying Works																																																																					
Fresh Water / Salt Water Mainlaying																																																																					
E&M Installation																																																																					
E&M Installation for Ancillary Buildings																																																																					
E&M Installation for Relocated DHSRs and Pumping Stations																																																																					
Other Associated Works																																																																					
Slope, Landscaping Works and Reinstatement for Access Tunnel Portal																																																																					
Predicted Noise Level during Daytime Period, dB(A)																																																																					

Predicted Noise Level exceeded the corresponding EIAO-TM noise criteria of 75 dB(A)

Note:
 [1] Distance Correction for PMEs = 10*log(2*PI*r²) [where PI = 3.1416 and r is the distance of NSR from notional noise source]
 [2] The figures are rounded-up to a whole number.

Construction Noise Assessment (Mitigated Scenario 1)

NSR 4

Chun Wai House, Tin Ma Court

Representative Floor: 1										mPD Level: 57		(Low Level)																																																																					
Activity	Works ID	Works Area	Hor. Dist. m	mPD Level	SWL dB(A)	Distance m	Corr. for Distance dB(A) [1][2]	Corr. for Topo	Corr. for façade dB(A)	2023												2024												2025												2026												2027																							
										4	5	6	7	8	9	10	11	12	1	2	3	4	5	6	7	8	9	10	11	12	1	2	3	4	5	6	7	8	9	10	11	12	1	2	3	4	5	6	7	8	9	10	11	12	1	2	3	4	5	6	7	8	9	10	11	12															
General										Site Mobilization																																																																							
Cavern and Tunnel Construction										Open-cut Construction of Tunnel and Tunnel Portal																																																																							
										Excavation of Access Tunnel																																																																							
										Excavation of Cavern																																																																							
										Stone Crushing																																																																							
Structural Works										Ancillary Buildings at Tunnel Portal																																																																							
										Structural Works for Relocated DHSRs and Pumping Stations																																																																							
Mainlaying Works										Fresh Water / Salt Water Mainlaying																																																																							
E&M Installation										E&M Installation for Ancillary Buildings																																																																							
										E&M installation for Relocated DHSRs and Pumping Stations																																																																							
Other Associated Works										Slope, Landscaping Works and Reinstatement for Access Tunnel Portal																																																																							
										Predicted Noise Level during Daytime Period, dB(A)												0												65												66												66												66											

Representative Floor: 19										mPD Level: 105		(Mid Level)																																																																					
Activity	Works ID	Works Area	Hor. Dist. m	mPD Level	SWL dB(A)	Distance m	Corr. for Distance dB(A) [1][2]	Corr. for Topo	Corr. for façade dB(A)	2023												2024												2025												2026												2027																							
										4	5	6	7	8	9	10	11	12	1	2	3	4	5	6	7	8	9	10	11	12	1	2	3	4	5	6	7	8	9	10	11	12	1	2	3	4	5	6	7	8	9	10	11	12	1	2	3	4	5	6	7	8	9	10	11	12															
General										Site Mobilization																																																																							
Cavern and Tunnel Construction										Open-cut Construction of Tunnel and Tunnel Portal																																																																							
										Excavation of Access Tunnel																																																																							
										Excavation of Cavern																																																																							
										Stone Crushing																																																																							
Structural Works										Ancillary Buildings at Tunnel Portal																																																																							
										Structural Works for Relocated DHSRs and Pumping Stations																																																																							
Mainlaying Works										Fresh Water / Salt Water Mainlaying																																																																							
E&M Installation										E&M Installation for Ancillary Buildings																																																																							
										E&M Installation for Relocated DHSRs and Pumping Stations																																																																							
Other Associated Works										Slope, Landscaping Works and Reinstatement for Access Tunnel Portal																																																																							
										Predicted Noise Level during Daytime Period, dB(A)												0												65												66												66												66											

Representative Floor: 37										mPD Level: 153		(High Level)																																																									
Activity	Works ID	Works Area	Hor. Dist. m	mPD Level	SWL dB(A)	Distance m	Corr. for Distance dB(A) [1][2]	Corr. for Topo	Corr. for façade dB(A)	2023												2024												2025												2026												2027											
										4	5	6	7	8	9	10	11	12	1	2	3	4	5	6	7	8	9	10	11	12	1	2	3	4	5	6	7	8	9	10	11	12	1	2	3	4	5	6	7	8	9	10	11	12	1	2	3	4	5	6	7	8	9	10	11	12			
General										Site Mobilization												56																																															
Cavern and Tunnel Construction										Open-cut Construction of Tunnel and Tunnel Portal												61												61												61												61											
										Excavation of Access Tunnel												55												55												55												55											
										Excavation of Cavern												80												103												560												-63											
										Stone Crushing												59												59												59												59											
Structural Works										Ancillary Buildings at Tunnel Portal																																																											
										Structural Works for Relocated DHSRs and Pumping Stations																																																											
Mainlaying Works										Fresh Water / Salt Water Mainlaying												46												46												46												46											
E&M Installation										E&M Installation for Ancillary Buildings																																																											
										E&M Installation for Relocated DHSRs and Pumping Stations																																																											
Other Associated Works										Slope, Landscaping Works and Reinstatement for Access Tunnel Portal																																																											
										Predicted Noise Level during Daytime Period, dB(A)												0												63												64												64											

Predicted Noise Level exceeded the corresponding EIAO-TM noise criteria of 75 dB(A)

Note:
 [1] Distance Correction for PMEs = 10*log(2*PI*r^2) [where PI = 3.1416 and r is the distance of NSR from notional noise source]
 [2] The figures are rounded-up to a whole number.

Construction Noise Assessment (Mitigated Scenario 1)

NSR 9

Pang Ching Court

Representative Floor: 1										mPD Level: 73 (Low Level)																																																											
Activity	Works ID	Works Area	Hor. Dist. m	mPD Level	SWL dB(A)	Distance m	Corr. for Distance dB(A) [1][2]	Corr. for Topo	Corr. for façade dB(A)	2023												2024												2025												2026												2027											
										4	5	6	7	8	9	10	11	12	1	2	3	4	5	6	7	8	9	10	11	12	1	2	3	4	5	6	7	8	9	10	11	12	1	2	3	4	5	6	7	8	9	10	11	12	1	2	3	4	5	6	7	8	9	10	11	12			
General																																																																					
Site Mobilization																																																																					
Cavern and Tunnel Construction																																																																					
Open-cut Construction of Tunnel and Tunnel Portal																																																																					
Excavation of Access Tunnel																																																																					
Excavation of Cavern																																																																					
Stone Crushing																																																																					
Structural Works																																																																					
Ancillary Buildings at Tunnel Portal																																																																					
Structural Works for Relocated DHSRs and Pumping Stations																																																																					
Mainlaying Works																																																																					
Fresh Water / Salt Water Mainlaying																																																																					
E&M Installation																																																																					
E&M Installation for Ancillary Buildings																																																																					
E&M Installation for Relocated DHSRs and Pumping Stations																																																																					
Other Associated Works																																																																					
Slope, Landscaping Works and Reinstatement for Access Tunnel Portal																																																																					
Predicted Noise Level during Daytime Period, dB(A)																																																																					

Representative Floor: 17										mPD Level: 118 (Mid Level)																																																											
Activity	Works ID	Works Area	Hor. Dist. m	mPD Level	SWL dB(A)	Distance m	Corr. for Distance dB(A) [1][2]	Corr. for Topo	Corr. for façade dB(A)	2023												2024												2025												2026												2027											
										4	5	6	7	8	9	10	11	12	1	2	3	4	5	6	7	8	9	10	11	12	1	2	3	4	5	6	7	8	9	10	11	12	1	2	3	4	5	6	7	8	9	10	11	12	1	2	3	4	5	6	7	8	9	10	11	12			
General																																																																					
Site Mobilization																																																																					
Cavern and Tunnel Construction																																																																					
Open-cut Construction of Tunnel and Tunnel Portal																																																																					
Excavation of Access Tunnel																																																																					
Excavation of Cavern																																																																					
Stone Crushing																																																																					
Structural Works																																																																					
Ancillary Buildings at Tunnel Portal																																																																					
Structural Works for Relocated DHSRs and Pumping Stations																																																																					
Mainlaying Works																																																																					
Fresh Water / Salt Water Mainlaying																																																																					
E&M Installation																																																																					
E&M Installation for Ancillary Buildings																																																																					
E&M Installation for Relocated DHSRs and Pumping Stations																																																																					
Other Associated Works																																																																					
Slope, Landscaping Works and Reinstatement for Access Tunnel Portal																																																																					
Predicted Noise Level during Daytime Period, dB(A)																																																																					

Representative Floor: 34										mPD Level: 166 (High Level)																																																											
Activity	Works ID	Works Area	Hor. Dist. m	mPD Level	SWL dB(A)	Distance m	Corr. for Distance dB(A) [1][2]	Corr. for Topo	Corr. for façade dB(A)	2023												2024												2025												2026												2027											
										4	5	6	7	8	9	10	11	12	1	2	3	4	5	6	7	8	9	10	11	12	1	2	3	4	5	6	7	8	9	10	11	12	1	2	3	4	5	6	7	8	9	10	11	12	1	2	3	4	5	6	7	8	9	10	11	12			
General																																																																					
Site Mobilization																																																																					
Cavern and Tunnel Construction																																																																					
Open-cut Construction of Tunnel and Tunnel Portal																																																																					
Excavation of Access Tunnel																																																																					
Excavation of Cavern																																																																					
Stone Crushing																																																																					
Structural Works																																																																					
Ancillary Buildings at Tunnel Portal																																																																					
Structural Works for Relocated DHSRs and Pumping Stations																																																																					
Mainlaying Works																																																																					
Fresh Water / Salt Water Mainlaying																																																																					
E&M Installation																																																																					
E&M Installation for Ancillary Buildings																																																																					
E&M Installation for Relocated DHSRs and Pumping Stations																																																																					
Other Associated Works																																																																					
Slope, Landscaping Works and Reinstatement for Access Tunnel Portal																																																																					
Predicted Noise Level during Daytime Period, dB(A)																																																																					

Predicted Noise Level exceeded the corresponding EIAO-TM noise criteria of 75 dB(A)

Note:
 [1] Distance Correction for PMEs = 10*log(2*PI*r²) [where PI = 3.1416 and r is the distance of NSR from notional noise source]
 [2] The figures are rounded-up to a whole number.

Construction Noise Assessment (Mitigated Scenario 1)

NSR 10 Chung Yuen House, Chuk Yuen North Estate

Activity	Works ID	Works Area	Hor. Dist. m	mPD Level	SWL dB(A)	Distance m	Corr. for Distance dB(A) [1][2]	Corr. for Topo	Corr. for façade dB(A)	mPD Level: 67 (Low Level)																																																																										
										2023												2024												2025												2026												2027																										
										4	5	6	7	8	9	10	11	12	1	2	3	4	5	6	7	8	9	10	11	12	1	2	3	4	5	6	7	8	9	10	11	12	1	2	3	4	5	6	7	8	9	10	11	12	1	2	3	4	5	6	7	8	9	10	11	12																		
General													Site Mobilization																																																																							
Cavern and Tunnel Construction													Open-cut Construction of Tunnel and Tunnel Portal																																																																							
													Excavation of Access Tunnel																																																																							
													Excavation of Cavern																																																																							
													Stone Crushing																																																																							
Structural Works													Ancillary Buildings at Tunnel Portal																																																																							
													Structural Works for Relocated DHSRs and Pumping Stations																																																																							
Mainlaying Works													Fresh Water / Salt Water Mainlaying																																																																							
E&M Installation													E&M Installation for Ancillary Buildings																																																																							
													E&M Installation for Relocated DHSRs and Pumping Stations																																																																							
Other Associated Works													Slope, Landscaping Works and Reinstatement for Access Tunnel Portal																																																																							
													Predicted Noise Level during Daytime Period, dB(A)												0												48												59												59												59											

Activity	Works ID	Works Area	Hor. Dist. m	mPD Level	SWL dB(A)	Distance m	Corr. for Distance dB(A) [1][2]	Corr. for Topo	Corr. for façade dB(A)	mPD Level: 112 (Mid Level)																																																																										
										2023												2024												2025												2026												2027																										
										4	5	6	7	8	9	10	11	12	1	2	3	4	5	6	7	8	9	10	11	12	1	2	3	4	5	6	7	8	9	10	11	12	1	2	3	4	5	6	7	8	9	10	11	12	1	2	3	4	5	6	7	8	9	10	11	12																		
General													Site Mobilization																																																																							
Cavern and Tunnel Construction													Open-cut Construction of Tunnel and Tunnel Portal																																																																							
													Excavation of Access Tunnel																																																																							
													Excavation of Cavern																																																																							
													Stone Crushing																																																																							
Structural Works													Ancillary Buildings at Tunnel Portal																																																																							
													Structural Works for Relocated DHSRs and Pumping Stations																																																																							
Mainlaying Works													Fresh Water / Salt Water Mainlaying																																																																							
E&M Installation													E&M Installation for Ancillary Buildings																																																																							
													E&M Installation for Relocated DHSRs and Pumping Stations																																																																							
Other Associated Works													Slope, Landscaping Works and Reinstatement for Access Tunnel Portal																																																																							
													Predicted Noise Level during Daytime Period, dB(A)												0												48												52												52												52											

Activity	Works ID	Works Area	Hor. Dist. m	mPD Level	SWL dB(A)	Distance m	Corr. for Distance dB(A) [1][2]	Corr. for Topo	Corr. for façade dB(A)	mPD Level: 159 (High Level)																																																														
										2023												2024												2025												2026												2027														
										4	5	6	7	8	9	10	11	12	1	2	3	4	5	6	7	8	9	10	11	12	1	2	3	4	5	6	7	8	9	10	11	12	1	2	3	4	5	6	7	8	9	10	11	12	1	2	3	4	5	6	7	8	9	10	11	12						
General													Site Mobilization																																																											
Cavern and Tunnel Construction													Open-cut Construction of Tunnel and Tunnel Portal																																																											
													Excavation of Access Tunnel																																																											
													Excavation of Cavern																																																											
													Stone Crushing																																																											
Structural Works													Ancillary Buildings at Tunnel Portal																																																											
													Structural Works for Relocated DHSRs and Pumping Stations																																																											
Mainlaying Works													Fresh Water / Salt Water Mainlaying																																																											
E&M Installation													E&M Installation for Ancillary Buildings																																																											
													E&M Installation for Relocated DHSRs and Pumping Stations																																																											
Other Associated Works													Slope, Landscaping Works and Reinstatement for Access Tunnel Portal																																																											
													Predicted Noise Level during Daytime Period, dB(A)												0												48												50												50											

Predicted Noise Level exceeded the corresponding EIAO-TM noise criteria of 75 dB(A)

Note:
 [1] Distance Correction for PMEs = 10*log(2*PI*r^2) [where PI = 3.1416 and r is the distance of NSR from notional noise source]
 [2] The figures are rounded-up to a whole number.

Construction Noise Assessment (Mitigated Scenario 1)

NSR 17 Ying Fuk Court

Representative Floor:		1		mPD Level:		58		(Low Level)		2023												2024												2025												2026												2027											
Activity	Works ID	Works Area	Hor. Dist. m	mPD Level	SWL dB(A)	Distance m	Corr. for Distance dB(A) [1][2]	Corr. for Topo	Corr. for façade dB(A)	4	5	6	7	8	9	10	11	12	1	2	3	4	5	6	7	8	9	10	11	12	1	2	3	4	5	6	7	8	9	10	11	12	1	2	3	4	5	6	7	8	9	10	11	12	1	2	3	4	5	6	7	8	9	10	11	12			
General																																																																					
Site Mobilization																																																																					
Cavern and Tunnel Construction																																																																					
Open-cut Construction of Tunnel and Tunnel Portal																																																																					
Excavation of Access Tunnel																																																																					
Excavation of Cavern																																																																					
Stone Crushing																																																																					
Structural Works																																																																					
Ancillary Buildings at Tunnel Portal																																																																					
Structural Works for Relocated DHSRs and Pumping Stations																																																																					
Mainlaying Works																																																																					
Fresh Water / Salt Water Mainlaying																																																																					
E&M Installation																																																																					
E&M Installation for Ancillary Buildings																																																																					
E&M Installation for Relocated DHSRs and Pumping Stations																																																																					
Other Associated Works																																																																					
Slope, Landscaping Works and Reinstatement for Access Tunnel Portal																																																																					
Predicted Noise Level during Daytime Period, dB(A)																																																																					

Representative Floor:		19		mPD Level:		107		(Mid Level)		2023												2024												2025												2026												2027											
Activity	Works ID	Works Area	Hor. Dist. m	mPD Level	SWL dB(A)	Distance m	Corr. for Distance dB(A) [1][2]	Corr. for Topo	Corr. for façade dB(A)	4	5	6	7	8	9	10	11	12	1	2	3	4	5	6	7	8	9	10	11	12	1	2	3	4	5	6	7	8	9	10	11	12	1	2	3	4	5	6	7	8	9	10	11	12	1	2	3	4	5	6	7	8	9	10	11	12			
General																																																																					
Site Mobilization																																																																					
Cavern and Tunnel Construction																																																																					
Open-cut Construction of Tunnel and Tunnel Portal																																																																					
Excavation of Access Tunnel																																																																					
Excavation of Cavern																																																																					
Stone Crushing																																																																					
Structural Works																																																																					
Ancillary Buildings at Tunnel Portal																																																																					
Structural Works for Relocated DHSRs and Pumping Stations																																																																					
Mainlaying Works																																																																					
Fresh Water / Salt Water Mainlaying																																																																					
E&M Installation																																																																					
E&M Installation for Ancillary Buildings																																																																					
E&M Installation for Relocated DHSRs and Pumping Stations																																																																					
Other Associated Works																																																																					
Slope, Landscaping Works and Reinstatement for Access Tunnel Portal																																																																					
Predicted Noise Level during Daytime Period, dB(A)																																																																					

Representative Floor:		37		mPD Level:		155		(High Level)		2023												2024												2025												2026												2027											
Activity	Works ID	Works Area	Hor. Dist. m	mPD Level	SWL dB(A)	Distance m	Corr. for Distance dB(A) [1][2]	Corr. for Topo	Corr. for façade dB(A)	4	5	6	7	8	9	10	11	12	1	2	3	4	5	6	7	8	9	10	11	12	1	2	3	4	5	6	7	8	9	10	11	12	1	2	3	4	5	6	7	8	9	10	11	12	1	2	3	4	5	6	7	8	9	10	11	12			
General																																																																					
Site Mobilization																																																																					
Cavern and Tunnel Construction																																																																					
Open-cut Construction of Tunnel and Tunnel Portal																																																																					
Excavation of Access Tunnel																																																																					
Excavation of Cavern																																																																					
Stone Crushing																																																																					
Structural Works																																																																					
Ancillary Buildings at Tunnel Portal																																																																					
Structural Works for Relocated DHSRs and Pumping Stations																																																																					
Mainlaying Works																																																																					
Fresh Water / Salt Water Mainlaying																																																																					
E&M Installation																																																																					
E&M Installation for Ancillary Buildings																																																																					
E&M Installation for Relocated DHSRs and Pumping Stations																																																																					
Other Associated Works																																																																					
Slope, Landscaping Works and Reinstatement for Access Tunnel Portal																																																																					
Predicted Noise Level during Daytime Period, dB(A)																																																																					

Predicted Noise Level exceeded the corresponding EIAO-TM noise criteria of 75 dB(A)

Note:
 [1] Distance Correction for PMEs = 10*log(2*PI*r²) [where PI = 3.1416 and r is the distance of NSR from notional noise source]
 [2] The figures are rounded-up to a whole number.

Construction Noise Assessment (Mitigated Scenario 1)

NSR 23

Lok Shing House, Tsz Lok Estate

Representative Floor:		mPD Level: 70 (Low Level)										2023												2024												2025												2026												2027											
Activity	Works ID	Works Area	Hor. Dist. m	mPD Level	SWL dB(A)	Distance m	Corr. for Distance dB(A) [1][2]	Corr. for Topo	Corr. for façade dB(A)	4	5	6	7	8	9	10	11	12	1	2	3	4	5	6	7	8	9	10	11	12	1	2	3	4	5	6	7	8	9	10	11	12	1	2	3	4	5	6	7	8	9	10	11	12	1	2	3	4	5	6	7	8	9	10	11	12					
General																																																																							
Site Mobilization																																																																							
Cavern and Tunnel Construction																																																																							
Open-cut Construction of Tunnel and Tunnel Portal																																																																							
Excavation of Access Tunnel																																																																							
Excavation of Cavern																																																																							
Stone Crushing																																																																							
Structural Works																																																																							
Ancillary Buildings at Tunnel Portal																																																																							
Structural Works for Relocated DHSRs and Pumping Stations																																																																							
Mainlaying Works																																																																							
Fresh Water / Salt Water Mainlaying																																																																							
E&M Installation																																																																							
E&M Installation for Ancillary Buildings																																																																							
E&M Installation for Relocated DHSRs and Pumping Stations																																																																							
Other Associated Works																																																																							
Slope, Landscaping Works and Reinstatement for Access Tunnel Portal																																																																							
Predicted Noise Level during Daytime Period, dB(A)																																																																							

Representative Floor:		mPD Level: 120 (Mid Level)										2023												2024												2025												2026												2027											
Activity	Works ID	Works Area	Hor. Dist. m	mPD Level	SWL dB(A)	Distance m	Corr. for Distance dB(A) [1][2]	Corr. for Topo	Corr. for façade dB(A)	4	5	6	7	8	9	10	11	12	1	2	3	4	5	6	7	8	9	10	11	12	1	2	3	4	5	6	7	8	9	10	11	12	1	2	3	4	5	6	7	8	9	10	11	12	1	2	3	4	5	6	7	8	9	10	11	12					
General																																																																							
Site Mobilization																																																																							
Cavern and Tunnel Construction																																																																							
Open-cut Construction of Tunnel and Tunnel Portal																																																																							
Excavation of Access Tunnel																																																																							
Excavation of Cavern																																																																							
Stone Crushing																																																																							
Structural Works																																																																							
Ancillary Buildings at Tunnel Portal																																																																							
Structural Works for Relocated DHSRs and Pumping Stations																																																																							
Mainlaying Works																																																																							
Fresh Water / Salt Water Mainlaying																																																																							
E&M Installation																																																																							
E&M Installation for Ancillary Buildings																																																																							
E&M Installation for Relocated DHSRs and Pumping Stations																																																																							
Other Associated Works																																																																							
Slope, Landscaping Works and Reinstatement for Access Tunnel Portal																																																																							
Predicted Noise Level during Daytime Period, dB(A)																																																																							

Representative Floor:		mPD Level: 173 (High Level)										2023												2024												2025												2026												2027											
Activity	Works ID	Works Area	Hor. Dist. m	mPD Level	SWL dB(A)	Distance m	Corr. for Distance dB(A) [1][2]	Corr. for Topo	Corr. for façade dB(A)	4	5	6	7	8	9	10	11	12	1	2	3	4	5	6	7	8	9	10	11	12	1	2	3	4	5	6	7	8	9	10	11	12	1	2	3	4	5	6	7	8	9	10	11	12	1	2	3	4	5	6	7	8	9	10	11	12					
General																																																																							
Site Mobilization																																																																							
Cavern and Tunnel Construction																																																																							
Open-cut Construction of Tunnel and Tunnel Portal																																																																							
Excavation of Access Tunnel																																																																							
Excavation of Cavern																																																																							
Stone Crushing																																																																							
Structural Works																																																																							
Ancillary Buildings at Tunnel Portal																																																																							
Structural Works for Relocated DHSRs and Pumping Stations																																																																							
Mainlaying Works																																																																							
Fresh Water / Salt Water Mainlaying																																																																							
E&M Installation																																																																							
E&M Installation for Ancillary Buildings																																																																							
E&M Installation for Relocated DHSRs and Pumping Stations																																																																							
Other Associated Works																																																																							
Slope, Landscaping Works and Reinstatement for Access Tunnel Portal																																																																							
Predicted Noise Level during Daytime Period, dB(A)																																																																							

Predicted Noise Level exceeded the corresponding EIAO-TM noise criteria of 75 dB(A)

Note:
 [1] Distance Correction for PMEs = 10*log(2*PI*r²) [where PI = 3.1416 and r is the distance of NSR from notional noise source]
 [2] The figures are rounded-up to a whole number.

Construction Noise Assessment (Mitigated Scenario 1)

NSR P1 Sheung Fung Street Customs Staff Quarters

Representative Floor:		1		mPD Level:						65 (Low Level)																																																											
Activity	Works ID	Works Area	Hor. Dist. m	mPD Level	SWL dB(A)	Distance m	Corr. for Distance dB(A) [1][2]	Corr. for Topo	Corr. for façade dB(A)	2023				2024				2025				2026				2027																																											
										4	5	6	7	8	9	10	11	12	1	2	3	4	5	6	7	8	9	10	11	12	1	2	3	4	5	6	7	8	9	10	11	12																											
General																						Site Mobilization		1-1	C	1320	77	102	1320	-70	0	3	35																																				
Cavern and Tunnel Construction																						Open-cut Construction of Tunnel and Tunnel Portal		2-1	C	1320	77	107	1320	-70	0	3	40	40	40	40	40	40	40	40	40	40	40	40	40	40	40	40	40	40	40	40																	
																						Excavation of Access Tunnel		2-2	B	1134	78	103	1134	-69	0	3	36	36	36	36	36	36	36	36	36	36	36	36	36	36	36	36	36	36	36	36																	
																						Excavation of Cavern		2-3	A	923	80	103	923	-67	0	3													38	38	38	38	38	38	38	38	38	38	38	38													
																						Stone Crushing		2-4	F	1340	77	105	1340	-71	0	3	37	37	37	37	37	37	37	37	37	37	37	37	37	37	37	37	37	37	37	37																	
Structural Works																						Ancillary Buildings at Tunnel Portal		3-1	C	1320	77	106	1320	-70	0	3													39	39	39	39	39	39	39	39	39	39	39	39													
																						Structural Works for Relocated DHSRs and Pumping Stations		3-2	A	923	80	89	923	-67	0	3													25	25	25	25	25	25	25	25	25	25	25	25													
Mainlaying Works																						Fresh Water / Salt Water Mainlaying		4-1	D	8	62	90	8	-26	0	3	67	67	67	67	67	67	67	67	67	67	67	67	67	67	67	67	67	67	67	67																	
E&M Installation																						E&M Installation for Ancillary Buildings		5-1	E	1333	77	102	1333	-70	0	3													34	34	34	34	34	34	34	34	34	34	34	34													
																						E&M Installation for Relocated DHSRs and Pumping Stations		5-2	A	923	80	89	923	-67	0	3													25	25	25	25	25	25	25	25	25	25	25	25													
Other Associated Works																						Slope, Landscaping Works and Reinstatement for Access Tunnel Portal		6-1	C	1320	77	98	1320	-70	0	3	0	42	67	67	67	67	67	67	67	67	67	67	67	67	67	67	67	67	67	67	31	31	31	31	31	31	31	31	31	31	31	31					
																						Predicted Noise Level during Daytime Period, dB(A)												0	42	67	67	67	67	67	67	67	67	67	67	67	67	67	67	67	67	67	67	31	31	31	31	31	31	31	31	31	31	31	31				

Representative Floor:		13		mPD Level:						100 (Mid Level)																																																											
Activity	Works ID	Works Area	Hor. Dist. m	mPD Level	SWL dB(A)	Distance m	Corr. for Distance dB(A) [1][2]	Corr. for Topo	Corr. for façade dB(A)	2023				2024				2025				2026				2027																																											
										4	5	6	7	8	9	10	11	12	1	2	3	4	5	6	7	8	9	10	11	12	1	2	3	4	5	6	7	8	9	10	11	12																											
General																						Site Mobilization		1-1	C	1320	77	102	1321	-70	0	3	35																																				
Cavern and Tunnel Construction																						Open-cut Construction of Tunnel and Tunnel Portal		2-1	C	1320	77	107	1321	-70	0	3	40	40	40	40	40	40	40	40	40	40	40	40	40	40	40	40	40	40	40	40																	
																						Excavation of Access Tunnel		2-2	B	1134	78	103	1134	-69	0	3	36	36	36	36	36	36	36	36	36	36	36	36	36	36	36	36	36	36	36	36																	
																						Excavation of Cavern		2-3	A	923	80	103	923	-67	0	3													38	38	38	38	38	38	38	38	38	38	38	38													
																						Stone Crushing		2-4	F	1340	77	105	1341	-71	0	3	37	37	37	37	37	37	37	37	37	37	37	37	37	37	37	37	37	37	37	37																	
Structural Works																						Ancillary Buildings at Tunnel Portal		3-1	C	1320	77	106	1321	-70	0	3													39	39	39	39	39	39	39	39	39	39	39	39													
																						Structural Works for Relocated DHSRs and Pumping Stations		3-2	A	923	80	89	923	-67	0	3													25	25	25	25	25	25	25	25	25	25	25	25													
Mainlaying Works																						Fresh Water / Salt Water Mainlaying		4-1	D	8	62	90	38	-40	0	3	53	53	53	53	53	53	53	53	53	53	53	53	53	53	53	53	53	53	53	53																	
E&M Installation																						E&M Installation for Ancillary Buildings		5-1	E	1333	77	102	1333	-70	0	3													34	34	34	34	34	34	34	34	34	34	34	34													
																						E&M Installation for Relocated DHSRs and Pumping Stations		5-2	A	923	80	89	923	-67	0	3													25	25	25	25	25	25	25	25	25	25	25	25													
Other Associated Works																						Slope, Landscaping Works and Reinstatement for Access Tunnel Portal		6-1	C	1320	77	98	1321	-70	0	3	0	42	54	54	54	54	54	54	54	54	54	54	54	54	54	54	54	54	54	54	31	31	31	31	31	31	31	31	31	31	31	31					
																						Predicted Noise Level during Daytime Period, dB(A)												0	42	54	54	54	54	54	54	54	54	54	54	54	54	54	54	54	54	54	54	31	31	31	31	31	31	31	31	31	31	31	31				

Representative Floor:		25		mPD Level:						134 (High Level)																																																											
Activity	Works ID	Works Area	Hor. Dist. m	mPD Level	SWL dB(A)	Distance m	Corr. for Distance dB(A) [1][2]	Corr. for Topo	Corr. for façade dB(A)	2023				2024				2025				2026				2027																																											
										4	5	6	7	8	9	10	11	12	1	2	3	4	5	6	7	8	9	10	11	12	1	2	3	4	5	6	7	8	9	10	11	12																											
General																						Site Mobilization		1-1	C	1320	77	102	1322	-70	0	3	35																																				
Cavern and Tunnel Construction																						Open-cut Construction of Tunnel and Tunnel Portal		2-1	C	1320	77	107	1322	-70	0	3	40	40	40	40	40	40	40	40	40	40	40	40	40	40	40	40	40	40	40	40																	
																						Excavation of Access Tunnel		2-2	B	1134	78	103	1135	-69	0	3	36	36	36	36	36	36	36	36	36	36	36	36	36	36	36	36	36	36	36	36																	
																						Excavation of Cavern		2-3	A	923	80	103	925	-67	0	3													38	38	38	38	38	38	38	38	38	38	38	38													
																						Stone Crushing		2-4	F	1340	77	105	1342	-71	0	3	37	37	37	37	37	37	37	37	37	37	37	37	37	37	37	37	37	37	37	37																	
Structural Works																						Ancillary Buildings at Tunnel Portal		3-1	C	1320	77	106	1322	-70	0	3													39	39	39	39	39	39	39	39	39	39	39	39													
																						Structural Works for Relocated DHSRs and Pumping Stations		3-2	A	923	80	89	925	-67	0	3													25	25	25	25	25	25	25	25	25	25	25	25													
Mainlaying Works																						Fresh Water / Salt Water Mainlaying		4-1	D	8	62	90	73	-45	0	3	48	48	48	48	48	48	48	48	48	48	48	48	48	48	48	48	48	48	48	48																	
E&M Installation																						E&M Installation for Ancillary Buildings		5-1	E	1333	77	102	1334	-70	0	3													34	34	34	34	34	34	34	34	34	34	34	34													
																						E&M Installation for Relocated DHSRs and Pumping Stations		5-2	A	923	80	89	925	-67	0	3													25	25	25	25	25	25	25	25	25	25	25	25													
Other Associated Works																						Slope, Landscaping Works and Reinstatement for Access Tunnel Portal		6-1	C	1320	77	98	1322	-70	0	3	0	42	49	49	49	49	49	49	49	49	49	49	49	49	49	49	49	49	49	49	31	31	31	31	31	31	31	31	31	31	31	31					
																						Predicted Noise Level during Daytime Period, dB(A)												0	42	49	49	49	49	49	49	49	49	49	49	49	49	49	49	49	49	49	49	31	31	31	31	31	31	31	31	31	31	31	31				

Predicted Noise Level exceeded the corresponding EIAO-TM noise criteria of 75 dB(A)

Note:
 [1] Distance Correction for PMEs = 10*log(2*PI*r²) [where PI = 3.1416 and r is the distance of NSR from notional noise source]
 [2] The figures are rounded-up to a whole number.

Appendix 4F: Cumulative Construction Noise Impact (Mitigated Scenario 1)

NSR No.	Description	Concurrent Project - Pedestrian Link near Chuk Yuen North Estate					Max. Predicted Mitigated CNL for this Project, dB(A)	Max. Predicted Cumulative CNL, dB(A)
		Max. SWL, dB(A)	Distance from Notional Noise Source of Current Project, m	Corr. for Distance, dB(A) [1][2]	Corr. for façade, dB(A)	Max. Predicted Mitigated CNL for Concurrent Project, dB(A)		
NSR 12	Mui Yuen House, Chuk Yuen North Estate	103	18	-33	3	73	56	73
NSR 13	Our Lady of Maryknoll Hospital	103	69	-45	3	61	72	72
NSR 14	Our Lady's College	103	119	-49	3	57	70	70
NSR 15	Evangel Children's Home	103	63	-44	3	62	66	67
NSR 16	Wing Shing House	103	190	-54	3	52	66	66
NSR 17	Ying Fuk Court	103	150	-51	3	55	51	56
NSR 18	Diamond Hill Kwong Yum Home for the Aged	103	90	-47	3	59	62	64
NSR 19	St. Bonaventure College and High School	103	180	-53	3	53	69	69
NSR 20	Wu York Yu Health Centre	103	231	-55	3	51	68	68
NSR 21	Twghs Wong Tai Sin Hospital	103	188	-53	3	53	55	57
NSR 22	Ho Lap Primary School	103	288	-57	3	49	57	58
NSR P1	Proposed Departmental Quarters for Customs & Excise Department	103	264	-56	3	50	67	67

NSR No.	Description	Concurrent Project - Improvement of Lion Rock Tunnel					Max. Predicted Mitigated CNL for this Project, dB(A)	Max. Predicted Cumulative CNL, dB(A)
		Max. SWL, dB(A)	Distance from Notional Noise Source of Current Project, m	Corr. for Distance, dB(A) [1][2]	Corr. for façade, dB(A)	Max. Predicted Mitigated CNL for Concurrent Project, dB(A)		
NSR 1	Block B, Peninsula Heights	117	101	-48	3	72	71	75
NSR 2	Block 1, Meridian Hill	117	222	-55	3	65	72	73
NSR 3	Chun Sing House, Tin Ma Court	117	353	-59	3	61	66	67

Predicted Noise Level exceeded the corresponding EIAO-TM noise criteria of 75 db(A) for residential / 70 db(A) for school during normal school days

Predicted Noise Level exceeded the corresponding EIAO-TM noise criteria of 65db(A) for school during examination period

Note:

[1] Distance Correction for PMEs = $10 \cdot \log(2 \cdot \pi \cdot r^2)$ [where $\pi = 3.1416$ and r is the distance of NSR from notional noise source]

[2] The figures are rounded-up to a whole number.

Construction Plant Inventory (Mitigated Scenario 2)

Works ID	Activities	Plant	TM Ref. / Other Ref.	Unit SWL, dB(A)	No. of PME	On-time %	Type of Noise Control	Noise reduction, dB(A)	SWL, dB(A)	Total SWL, dB(A)
	General									
1-1	Site Mobilization - Excavation	Air Compressor, air flow > 10m ³ /min and < 30m ³ /min	EPD-12829 Brand: AIRMAN Model : PDS390S-5C1	98	1	100%	Enclosure	-10	88	102
		Breaker, excavator mounted (hydraulic)	(Ref: Sandhurst - XT-200) ^[4]	110	1	50%	Barrier	-5	102	
		Excavator/loader, wheeled/tracked	EPD-12806 Brand: KOBELCO Model : SK225SR	95	1	100%	Barrier	-5	90	
		Generator, silenced, 75dB(A) at 7m	EPD-13131 Brand :DENYO Model : DCA-220LSIE	93	1	50%	Enclosure	-10	80	
	Site Mobilization - Formation of works site	Concrete lorry mixer	[5]	103	1	40%	Barrier	-5	94	97
		Poker, vibratory, Hand-held (electric)	[6]	102	1	40%	Barrier	-5	93	
		Generator, silenced, 75dB(A) at 7m	EPD-08978	93	1	100%	Enclosure	-10	83	
	Site Mobilization - Mobilization of construction plants and materials	Crane, mobile	EPD-08588 Brand : Maeda Model : CC423S-1	93	1	45%				90
Dump truck, 5.5 tonne < gross vehicle weight ≤ 38 tonne		[2]	105	1	50%	Barrier	-5	97		
Generator, silenced, 75dB(A) at 7m		EPD-13131 Brand :DENYO Model : DCA-220LSIE	93	1	100%	Enclosure	-10	83		

Works ID	Activities	Plant	TM Ref. / Other Ref.	Unit SWL, dB(A)	No. of PME	On- time %	Type of Noise Control	Noise reduction, dB(A)	SWL, dB(A)	Total SWL, dB(A)	
	Cavern and Tunnel Construction										
2-1	Open-cut Construction of Tunnel and Tunnel Portal (Group 1)	Excavator/loader, wheeled/tracked	EPD-12806 Brand: KOBELCO Model : SK225SR	95	2	70%	Barrier	-5	91	107	
		Dump truck, 5.5 tonne < gross vehicle weight ≤ 38 tonne	[2]	105	1	70%	Barrier	-5	98		
		Air Compressor, air flow > 10m ³ /min and < 30m ³ /min	EPD-12829 Brand: AIRMAN Model : PDS390S-5C1	98	2	100%	Enclosure	-10	91		
		Piling, vibrating hammer	[2]	115	1	40%	Barrier	-5	106		
	Open-cut Construction of Tunnel and Tunnel Portal (Group 2)	Crawler crane	EPD-12661 Brand: SANY Model : SCC2500A	108	1	50%				105	107
		Poker, vibratory, Hand-held (electric)	[6]	102	1	50%	Barrier	-5	94		
		Saw, circular, wood	CNP 201	108	1	50%	Barrier	-5	100		
		Bar bender and cutter (electric)	CNP 021	90	2	50%	Barrier	-5	85		
		Water pump (electric)	CNP 281	88	2	80%	Barrier	-5	85		
		Concrete pump, stationary/lorry mounted	CNP 047	109	1	30%	Barrier	-5	99		
Concrete lorry mixer	[5]	103	1	50%	Barrier	-5	95				
2-2	Excavation of Access Tunnel	Rock drill, crawler mounted (hydraulic)	CNP 182	123	1	75%	Inside Cavern	-20	102	103	
		Breaker, excavator mounted (hydraulic)	(Ref: Sandhurst - XT-200) ^[4]	110	1	80%	Inside Cavern	-20	89		
		Water pump (electric)	CNP 281	88	2	80%	Inside Cavern	-20	70		
		Concrete pump, stationary/lorry mounted	CNP 047	109	1	60%	Inside Cavern	-20	87		
		Concrete lorry mixer	[5]	103	1	60%	Inside Cavern	-20	81		
		Dump truck, 5.5 tonne < gross vehicle weight ≤ 38 tonne	[2]	105	1	70%	Inside Cavern	-20	83		
		Ventilation fan	CNP 241	108	2	100%	Inside Cavern	-20	91		
		Conveyor Belt	CNP 041	90	1	100%	Inside Cavern	-20	70		
		2-3	Excavation of Cavern	Rock drill, crawler mounted (hydraulic)	CNP 182	123	1	75%	Inside Cavern		-20
Breaker, excavator mounted (hydraulic)	(Ref: Sandhurst - XT-200) ^[4]			110	1	80%	Inside Cavern	-20	89		
Water pump (electric)	CNP 281			88	2	80%	Inside Cavern	-20	70		
Concrete pump, stationary/lorry mounted	CNP 047			109	1	60%	Inside Cavern	-20	87		
Concrete lorry mixer	[5]			103	1	60%	Inside Cavern	-20	81		
Dump truck, 5.5 tonne < gross vehicle weight ≤ 38 tonne	[2]			105	1	70%	Inside Cavern	-20	83		
Ventilation fan	CNP 241			108	2	100%	Inside Cavern	-20	91		
Conveyor Belt	CNP 041			90	1	100%	Inside Cavern	-20	70		
2-4	Stone Crushing	Crusher	[7]	118	1	50%	Enclosure	-10	105	105	

Works ID	Activities	Plant	TM Ref. / Other Ref.	Unit SWL, dB(A)	No. of PME	On- time %	Type of Noise Control	Noise reduction, dB(A)	SWL, dB(A)	Total SWL, dB(A)
	Structural Works									
3-1	Ancillary Buildings at Tunnel Portal - Excavation	Air Compressor, air flow > 10m ³ /min and < 30m ³ /min	EPD-12829 Brand: AIRMAN Model : PDS390S-5C1	98	1	100%	Enclosure	-10	88	102
		Breaker, hand held, mass > 10kg and < 20kg	EPD-07425 Brand : MAKITA Model : HM1317C	103	1	50%	Barrier	-5	95	
		Excavator/loader, wheeled/tracked	EPD-12806 Brand: KOBELCO Model : SK225SR	95	2	70%	Barrier	-5	91	
		Dump truck, 5.5 tonne < gross vehicle weight ≤ 38 tonne	[2]	105	2	50%	Barrier	-5	100	
		Generator, silenced, 75dB(A) at 7m	EPD-13131 Brand :DENYO Model : DCA-220LSIE	93	1	100%	Enclosure	-10	83	
	Ancillary Buildings at Tunnel Portal - Foundation	Concrete lorry mixer	[5]	103	2	50%	Barrier	-5	98	106
		Concrete pump, stationary/lorry mounted	CNP 047	109	1	50%	Barrier	-5	101	
		Poker, vibratory, Hand-held (electric)	[6]	102	2	50%	Barrier	-5	97	
		Saw, circular, wood	CNP 201	108	2	60%	Barrier	-5	104	
		Bar bender and cutter (electric)	CNP 021	90	2	60%	Barrier	-5	86	
		Crane, mobile	EPD-08588 Brand : Maeda Model : CC423S-1	93	1	40%			89	
		Dump truck, 5.5 tonne < gross vehicle weight ≤ 38 tonne	[2]	105	1	50%	Barrier	-5	97	
	Generator, silenced, 75dB(A) at 7m	EPD-13131 Brand :DENYO Model : DCA-220LSIE	93	1	100%	Enclosure	-10	83		
	Ancillary Buildings at Tunnel Portal - Structural Works	Concrete pump, stationary/lorry mounted	CNP 047	109	1	50%	Barrier	-5	101	106
		Concrete lorry mixer	[5]	103	1	80%	Barrier	-5	97	
Poker, vibratory, Hand-held (electric)		[6]	102	2	80%	Barrier	-5	99		
Saw, circular, wood		CNP 201	108	1	60%	Barrier	-5	101		
Bar bender and cutter (electric)		CNP 021	90	1	70%	Barrier	-5	83		
Tower crane		CNP 049	95	1	60%			93		
Generator, silenced, 75dB(A) at 7m		EPD-13131 Brand :DENYO Model : DCA-220LSIE	93	1	100%	Enclosure	-10	83		
3-2	Structural Works for Relocated DHSRs and Pumping Stations	Crane, mobile	EPD-08588 Brand : Maeda Model : CC423S-1	93	1	70%	Inside Cavern	-20	71	89
		Concrete lorry mixer	[5]	103	1	80%	Inside Cavern	-20	82	
		Poker, vibratory, Hand-held (electric)	[6]	102	1	80%	Inside Cavern	-20	81	
		Generator, silenced, 75dB(A) at 7m	EPD-13131 Brand :DENYO Model : DCA-220LSIE	93	1	100%	Inside Cavern	-20	73	
		Saw, circular, wood	CNP 201	108	1	70%	Inside Cavern	-20	86	
		Bar bender and cutter (electric)	CNP 021	90	1	70%	Inside Cavern	-20	68	

Works ID	Activities	Plant	TM Ref. / Other Ref.	Unit SWL, dB(A)	No. of PME	On- time %	Type of Noise Control	Noise reduction, dB(A)	SWL, dB(A)	Total SWL, dB(A)
	<u>Mainlaying</u>									
4-1	Fresh Water / Salt Water Mainlaying - Surface Breaking	Hand-held Percussive Breaker	EPD-08782 Brand :Hilti Model : TE 1000-AVR	99	1	30%	Barrier	-5	89	90
		Generator, silenced, 75dB(A) at 7m	EPD-13131 Brand :DENYO Model : DCA-220LSIE	93	1	100%	Enclosure	-10	83	
	Fresh Water / Salt Water Mainlaying - Excavation & Pipe laying	Excavator/loader, wheeled/tracked	EPD-12806 Brand: KOBELCO Model : SK225SR	95	1	50%	Barrier	-5	87	87
	Fresh Water / Salt Water Mainlaying - Reinstatement (Group 1)	Concrete lorry mixer	[5]	103	1	50%	Barrier (Type 2)	-10	90	90
	Fresh Water / Salt Water Mainlaying - Reinstatement (Group 2)	Poker, vibratory, hand-held (electric)	[6]	102	1	50%	Barrier (Type 2)	-10	89	90
		Generator, silenced, 75 dB(A) at 7 m	EPD-13131 Brand :DENYO Model : DCA-220LSIE	93	1	100%	Enclosure	-10	83	
Fresh Water / Salt Water Mainlaying - Reinstatement (Group 3)	Asphalt paver	EPD-12785 Brand :JOSEPH VOEGELE AG / VOEGELE Model : SUPER 1603-3	104	1	40%	Barrier (Type 2)	-10	90	90	
Fresh Water / Salt Water Mainlaying - Reinstatement (Group 4)	Dump truck, 5.5 tonne < gross vehicle weight ≤ 38 tonne	[2]	105	1	30%	Barrier (Type 2)	-10	90	90	
Fresh Water / Salt Water Mainlaying - Reinstatement (Group 5)	Paint line marker	CNP 161	90	1	50%	Barrier	-5	82	82	
Fresh Water / Salt Water Mainlaying - Reinstatement (Group 6)	Road roller	EPD-12035 Brand : AMMANN Model : ARX40-2	101	1	50%	Barrier (Type 2)	-10	88	88	
Fresh Water / Salt Water Mainlaying - Reinstatement (Group 8)	Air blower (electric)	[2]	95	1	50%	Barrier	-5	87	90	
	Winch (electric)	CNP 262	95	1	50%	Barrier	-5	87		

Works ID	Activities	Plant	TM Ref. / Other Ref.	Unit SWL, dB(A)	No. of PME	On- time %	Type of Noise Control	Noise reduction, dB(A)	SWL, dB(A)	Total SWL, dB(A)
	<u>E&M Installation</u>									
5-1	E&M Installation for Ancillary Buildings	Lorry, with crane/grab, 5.5 tonne < gross vehicle weight \leq 38 tonne	[2]	105	1	100%	Barrier	-5	100	102
		Dump truck, 5.5 tonne < gross vehicle weight \leq 38 tonne	[2]	105	1	50%	Barrier	-5	97	
5-2	E&M Installation for Relocated DHSRs and Pumping Stations	Lorry, with crane/grab, 5.5 tonne < gross vehicle weight \leq 38 tonne	[2]	105	1	100%	Inside Cavern	-20	85	89
		Ventilation fan	CNP 241	108	1	70%	Inside Cavern	-20	86	
		Generator, silenced, 75 dB(A) at 7 m	EPD-13131 Brand :DENYO Model : DCA-220LSIE	93	1	100%	Inside Cavern	-20	73	

Works ID	Activities	Plant	TM Ref. / Other Ref.	Unit SWL, dB(A)	No. of PME	On- time %	Type of Noise Control	Noise reduction, dB(A)	SWL, dB(A)	Total SWL, dB(A)
	<u>Other Associated Works</u>									
6-1	Slope, Landscaping Works and Reinstatement for Access Tunnel Portal	Lorry, with crane/grab, 5.5 tonne < gross vehicle weight \leq 38 tonne	[2]	105	1	70%	Barrier	-5	98	98

Notes:

- [1] As only one group of PME would be operated simultaneously under same Works ID, only the activity with the highest total SWL under the same Works ID will be used for the construction noise assessment for each NSR
- [2] Sound power levels of other commonly used PME (http://www.epd.gov.hk/epd/sites/default/files/epd/english/application_for_licences/guidance/files/OtherSWLe.pdf)
- [3] Quality Powered Mechanical Equipment (https://www.epd.gov.hk/cgi-bin/npg/qpme/search_gen.pl?lang=eng&st=sim&valid=Y)
- [4] Reference for Sandhurst - XT-200 is made from EIA-235/2015 - Development of Anderson Road Quarry Site
- [5] Reference for Concrete Lorry Mixer is made from sound power level measurement report
- [6] Reference is made from EIA-235/2015 - Development of Anderson Road Quarry Site
- [7] Reference is made from AEIAR-126/2008 - West Island Line

Summary of Predicted Noise Levels from Construction (Mitigated Scenario 2)

NSR	Description	EIAO-TM Noise Criteria, dB(A)	Max. Predicted CNL, db(A)			
			Low Level	Mid Level	High Level	Overall
NSR 5	Grace Methodist Church Kindergarten	65 (examination period)	65	N/A	N/A	65
NSR 14	Our Lady's College	65 (examination period)	59	59	57	59
NSR 19	St. Bonaventure College and High School	65 (examination period)	59	58	55	59

During examination period, Fresh Water / Salt Water Mainlaying (Reinstatement Works) will be carried out 20m from the school site boundary.

Construction Noise Assessment (Mitigated Scenario 2)

NSR 19

		St. Bonaventure College and High School							(Examination Period)																																																																								
Representative Floor:		1							50 (Low Level)																																																																								
Activity	Works ID	Works Area	Hor. Dist. m	mPD Level	SWL dB(A)	Distance m	Corr. for Distance dB(A) [1][2]	Corr. for Topo	Corr. for façade dB(A)	2023												2024												2025												2026												2027																							
General										Site Mobilization												Open-cut Construction of Tunnel and Tunnel Portal												Excavation of Access Tunnel												Excavation of Cavern												Stone Crushing																							
Cavern and Tunnel Construction										Ancillary Buildings at Tunnel Portal												Structural Works for Relocated DHSRs and Pumping Stations												Fresh Water / Salt Water Mainlaying												E&M Installation for Ancillary Buildings												E&M Installation for Relocated DHSRs and Pumping Stations												Slope, Landscaping Works and Reinstatement for Access Tunnel Portal											
Structural Works										Fresh Water / Salt Water Mainlaying												E&M Installation for Ancillary Buildings												E&M Installation for Relocated DHSRs and Pumping Stations												Slope, Landscaping Works and Reinstatement for Access Tunnel Portal												Predicted Noise Level during Daytime Period, dB(A)																							

		4							62 (Mid Level)																																																																								
Representative Floor:		4							62 (Mid Level)																																																																								
Activity	Works ID	Works Area	Hor. Dist. m	mPD Level	SWL dB(A)	Distance m	Corr. for Distance dB(A) [1][2]	Corr. for Topo	Corr. for façade dB(A)	2023												2024												2025												2026												2027																							
General										Site Mobilization												Open-cut Construction of Tunnel and Tunnel Portal												Excavation of Access Tunnel												Excavation of Cavern												Stone Crushing																							
Cavern and Tunnel Construction										Ancillary Buildings at Tunnel Portal												Structural Works for Relocated DHSRs and Pumping Stations												Fresh Water / Salt Water Mainlaying												E&M Installation for Ancillary Buildings												E&M Installation for Relocated DHSRs and Pumping Stations												Slope, Landscaping Works and Reinstatement for Access Tunnel Portal											
Structural Works										Fresh Water / Salt Water Mainlaying												E&M Installation for Ancillary Buildings												E&M Installation for Relocated DHSRs and Pumping Stations												Slope, Landscaping Works and Reinstatement for Access Tunnel Portal												Predicted Noise Level during Daytime Period, dB(A)																							

		7							73 (Mid Level)																																																																								
Representative Floor:		7							73 (Mid Level)																																																																								
Activity	Works ID	Works Area	Hor. Dist. m	mPD Level	SWL dB(A)	Distance m	Corr. for Distance dB(A) [1][2]	Corr. for Topo	Corr. for façade dB(A)	2023												2024												2025												2026												2027																							
General										Site Mobilization												Open-cut Construction of Tunnel and Tunnel Portal												Excavation of Access Tunnel												Excavation of Cavern												Stone Crushing																							
Cavern and Tunnel Construction										Ancillary Buildings at Tunnel Portal												Structural Works for Relocated DHSRs and Pumping Stations												Fresh Water / Salt Water Mainlaying												E&M Installation for Ancillary Buildings												E&M Installation for Relocated DHSRs and Pumping Stations												Slope, Landscaping Works and Reinstatement for Access Tunnel Portal											
Structural Works										Fresh Water / Salt Water Mainlaying												E&M Installation for Ancillary Buildings												E&M Installation for Relocated DHSRs and Pumping Stations												Slope, Landscaping Works and Reinstatement for Access Tunnel Portal												Predicted Noise Level during Daytime Period, dB(A)																							

Note:
 [1] Distance Correction for PMEs = 10*log(2*PI*r^2) [where PI = 3.1416 and r is the distance of NSR from notional noise source]
 [2] The figures are rounded-up to a whole number.
 Remarks: During examination period, no mainlaying works will be carried out within 30m from the school site boundary.

Construction Noise Assessment (Mitigated Scenario 2)

NSR 20

Representative Floor: Wu York Yu Health Centre

Activity	Works ID	Works Area	Hor. Dist. m	mPD Level	SWL dB(A)	Distance m	mPD Level: 55 (Low Level)		2023-2027																																																															
							Corr. for Distance dB(A) [1][2]	Corr. for Topo	Corr. for façade dB(A)	2023												2024												2025												2026												2027														
										4	5	6	7	8	9	10	11	12	1	2	3	4	5	6	7	8	9	10	11	12	1	2	3	4	5	6	7	8	9	10	11	12	1	2	3	4	5	6	7	8	9	10	11	12	1	2	3	4	5	6	7	8	9	10	11	12						
General													Site Mobilization																																																											
Cavern and Tunnel Construction													Open-cut Construction of Tunnel and Tunnel Portal																																																											
													Excavation of Access Tunnel																																																											
													Excavation of Cavern																																																											
													Stone Crushing																																																											
Structural Works													Ancillary Buildings at Tunnel Portal																																																											
													Structural Works for Relocated DHSRs and Pumping Stations																																																											
Mainlaying Works													Fresh Water / Salt Water Mainlaying																																																											
E&M Installation													E&M Installation for Ancillary Buildings																																																											
													E&M Installation for Relocated DHSRs and Pumping Stations																																																											
Other Associated Works													Slope, Landscaping Works and Reinstatement for Access Tunnel Portal																																																											
													Predicted Noise Level during Daytime Period, dB(A)																																																											

Representative Floor: 2 mPD Level: 62 (Mid Level)

Activity	Works ID	Works Area	Hor. Dist. m	mPD Level	SWL dB(A)	Distance m	mPD Level: 62 (Mid Level)		2023-2027																																																															
							Corr. for Distance dB(A) [1][2]	Corr. for Topo	Corr. for façade dB(A)	2023												2024												2025												2026												2027														
										4	5	6	7	8	9	10	11	12	1	2	3	4	5	6	7	8	9	10	11	12	1	2	3	4	5	6	7	8	9	10	11	12	1	2	3	4	5	6	7	8	9	10	11	12	1	2	3	4	5	6	7	8	9	10	11	12						
General													Site Mobilization																																																											
Cavern and Tunnel Construction													Open-cut Construction of Tunnel and Tunnel Portal																																																											
													Excavation of Access Tunnel																																																											
													Excavation of Cavern																																																											
													Stone Crushing																																																											
Structural Works													Ancillary Buildings at Tunnel Portal																																																											
													Structural Works for Relocated DHSRs and Pumping Stations																																																											
Mainlaying Works													Fresh Water / Salt Water Mainlaying																																																											
E&M Installation													E&M Installation for Ancillary Buildings																																																											
													E&M Installation for Relocated DHSRs and Pumping Stations																																																											
Other Associated Works													Slope, Landscaping Works and Reinstatement for Access Tunnel Portal																																																											
													Predicted Noise Level during Daytime Period, dB(A)																																																											

Representative Floor: 3 mPD Level: 65 (High Level)

Activity	Works ID	Works Area	Hor. Dist. m	mPD Level	SWL dB(A)	Distance m	mPD Level: 65 (High Level)		2023-2027																																																															
							Corr. for Distance dB(A) [1][2]	Corr. for Topo	Corr. for façade dB(A)	2023												2024												2025												2026												2027														
										4	5	6	7	8	9	10	11	12	1	2	3	4	5	6	7	8	9	10	11	12	1	2	3	4	5	6	7	8	9	10	11	12	1	2	3	4	5	6	7	8	9	10	11	12	1	2	3	4	5	6	7	8	9	10	11	12						
General													Site Mobilization																																																											
Cavern and Tunnel Construction													Open-cut Construction of Tunnel and Tunnel Portal																																																											
													Excavation of Access Tunnel																																																											
													Excavation of Cavern																																																											
													Stone Crushing																																																											
Structural Works													Ancillary Buildings at Tunnel Portal																																																											
													Structural Works for Relocated DHSRs and Pumping Stations																																																											
Mainlaying Works													Fresh Water / Salt Water Mainlaying																																																											
E&M Installation													E&M Installation for Ancillary Buildings																																																											
													E&M Installation for Relocated DHSRs and Pumping Stations																																																											
Other Associated Works													Slope, Landscaping Works and Reinstatement for Access Tunnel Portal																																																											
													Predicted Noise Level during Daytime Period, dB(A)																																																											

Note:
 [1] Distance Correction for PMEs = 10*log(2^PI/r^2) [where PI = 3.1416 and r is the distance of NSR from notional noise source]
 [2] The figures are rounded-up to a whole number.

Remarks: Theconcrete lorry mixer, Road planer or miller and Road roller shall be located 10 m away from the residential site boundary during the construction works of Fresh Water/Salt Water Mainlaying (Reinstatement Works).

Construction Noise Assessment (Mitigated Scenario 2)

NSR 22

Representative Floor:		Ho Lap Primary School							(Normal School Days)																				
1		mPD Level:							64 (Low Level)																				
Activity	Works ID	Works Area	Hor. Dist. m	mPD Level	SWL dB(A)	Distance m	Corr. for Distance dB(A) [1][2]	Corr. for Topo	Corr. for façade dB(A)	2023				2024				2025				2026				2027			
General																													
Site Mobilization																													
Cavern and Tunnel Construction																													
Open-cut Construction of Tunnel and Tunnel Portal																													
Excavation of Access Tunnel																													
Excavation of Cavern																													
Stone Crushing																													
Structural Works																													
Ancillary Buildings at Tunnel Portal																													
Structural Works for Relocated DHSRs and Pumping Stations																													
Mainlaying Works																													
Fresh Water / Salt Water Mainlaying																													
E&M Installation																													
E&M Installation for Ancillary Buildings																													
E&M Installation for Relocated DHSRs and Pumping Stations																													
Other Associated Works																													
Slope, Landscaping Works and Reinstatement for Access Tunnel Portal																													
Predicted Noise Level during Daytime Period, dB(A)																													

Representative Floor:		3							mPD Level:																				
71 (Mid Level)		mPD Level:							71 (Mid Level)																				
Activity	Works ID	Works Area	Hor. Dist. m	mPD Level	SWL dB(A)	Distance m	Corr. for Distance dB(A) [1][2]	Corr. for Topo	Corr. for façade dB(A)	2023				2024				2025				2026				2027			
General																													
Site Mobilization																													
Cavern and Tunnel Construction																													
Open-cut Construction of Tunnel and Tunnel Portal																													
Excavation of Access Tunnel																													
Excavation of Cavern																													
Stone Crushing																													
Structural Works																													
Ancillary Buildings at Tunnel Portal																													
Structural Works for Relocated DHSRs and Pumping Stations																													
Mainlaying Works																													
Fresh Water / Salt Water Mainlaying																													
E&M Installation																													
E&M Installation for Ancillary Buildings																													
E&M Installation for Relocated DHSRs and Pumping Stations																													
Other Associated Works																													
Slope, Landscaping Works and Reinstatement for Access Tunnel Portal																													
Predicted Noise Level during Daytime Period, dB(A)																													

Representative Floor:		6							mPD Level:																				
82 (High Level)		mPD Level:							82 (High Level)																				
Activity	Works ID	Works Area	Hor. Dist. m	mPD Level	SWL dB(A)	Distance m	Corr. for Distance dB(A) [1][2]	Corr. for Topo	Corr. for façade dB(A)	2023				2024				2025				2026				2027			
General																													
Site Mobilization																													
Cavern and Tunnel Construction																													
Open-cut Construction of Tunnel and Tunnel Portal																													
Excavation of Access Tunnel																													
Excavation of Cavern																													
Stone Crushing																													
Structural Works																													
Ancillary Buildings at Tunnel Portal																													
Structural Works for Relocated DHSRs and Pumping Stations																													
Mainlaying Works																													
Fresh Water / Salt Water Mainlaying																													
E&M Installation																													
E&M Installation for Ancillary Buildings																													
E&M Installation for Relocated DHSRs and Pumping Stations																													
Other Associated Works																													
Slope, Landscaping Works and Reinstatement for Access Tunnel Portal																													
Predicted Noise Level during Daytime Period, dB(A)																													

Note:
 [1] Distance Correction for PMEs = $10 \cdot \log(2^{PI} r^2)$ [where PI = 3.1416 and r is the distance of NSR from notional noise source]
 [2] The figures are rounded-up to a whole number.

Appendix 4F: Cumulative Construction Noise Impact (Mitigated Scenario 2)

NSR No.	Description	Concurrent Project - Pedestrian Link near Chuk Yuen North Estate					Max. Predicted Mitigated CNL for this Project, dB(A)	Max. Predicted Mitigated CNL for this Project, dB(A)	Max. Predicted Cumulative CNL, dB(A)
		Max. SWL, dB(A)	Distance from Notional Noise Source of Current Project, m	Corr. for Distance, dB(A) [1][2]	Corr. for façade, dB(A)	Max. Predicted Mitigated CNL for Concurrent Project, dB(A)			
NSR 13	Our Lady of Maryknoll Hospital	103	69	-45	3	61	72	72	
NSR 14	Our Lady's College	103	119	-49	3	57	59	61	
		103	119	-49	3	57	56	59	
NSR 19	St. Bonaventure College and High School	103	180	-53	3	53	59	60	
		103	180	-53	3	53	56	58	
NSR 20	Wu York Yu Health Centre	103	231	-55	3	51	68	68	
NSR 22	Ho Lap Primary School	103	288	-57	3	49	57	58	
		103	288	-57	3	49	56	56	

Note:

[1] Distance Correction for PMEs = $10 \cdot \log(2 \cdot \text{PI} \cdot r^2)$ [where PI = 3.1416 and r is the distance of NSR from notional noise source]

[2] The figures are rounded-up to a whole number.

Contract No. 21/WSD/21

Relocation of Diamond Hill Fresh Water and Salt Water Reservoirs to Caverns

Appendix D – Details of Acoustic Noise Barriers



Model No. CK2009	High Tenacity Polyester PVC Laminated Fabrics
General Applications:	Construction, Marine (Field) covers, Storage covers and many other applications
Colors:	Yellow, Sky Blue, Green, Orange, Dark Green, White, Grey
Available Grades:	Fire-Retardant, Ultra-Violet, Anti-Mildew, Anti-Cold, Sound Insulated
Type of Products:	Roll Type
Raw Material Origin:	From Japan
Flammability Test Method:	BS 5867-2 2008
Sizes:	2M x 6M, 2M x 30M(roll type)

Sample name(provided by sponsor): PVC Tarpaulin
 Color: Gray
 Mass per unit area : 958 g/m²
 Area, S, of test element : 3.8 m²
 Air temp. in the test rooms : 27°C
 Relative humidity in the test rooms : 58%
 Receiving room volume : 67.9 m³

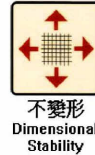

Physical Properties:

III. Test results

f Hz	R dB
100	10.1
125	11.6
160	8.6
200	5.9
250	7.3
315	9.1
400	9.4
500	10.0
630	9.9
800	11.5
1000	13.5
1250	15.5
1600	16.7
2000	17.0
2500	17.8
3150	18.9
4000	21.9
5000	23.9
Rw (C;Ctr)	14(-1;-2)

Fabric Detail 網布規格	1000D x 1000D x 20 x22		
Item 項目名稱	Test Method 執行標準	Unit 單位	Value 數據
Thickness 厚度	DIN53353	mm	1.0
Total Weight 總重量	DIN53352	g/m ²	1132.2
Tensile Strength 拉伸強度	DIN53354	N/5cm	經 Warp 3040 緯 Weft 2549
Elongation at Break 斷裂伸長率	DIN53354	%	經 Warp 17.3 緯 Weft 23.3
Tear Strength 撕裂強度	DIN53363	N	經 Warp 448 緯 Weft 374
Adhesion of Coating Strength 剝離負荷	DIN53357	N/5cm	經 Warp 123 緯 Weft 108
Remarks 備註			

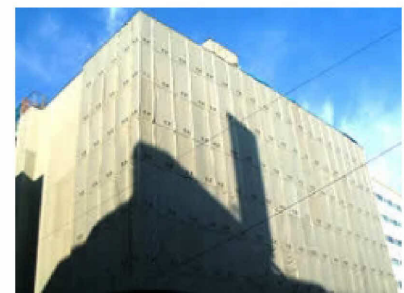
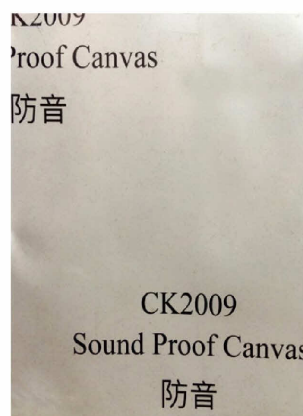
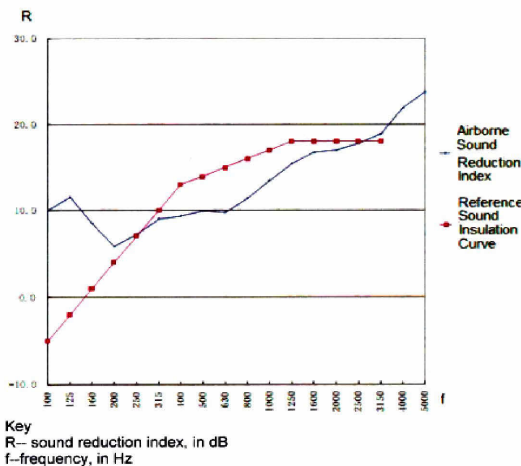

This technical data is offered as helpful suggestion only. It's accurate to the best of our knowledge at time of printing.

祥記帆布工程有限公司
Cheung Kee Canvas Ltd.

G/F, 352 Reclamation St., Kowloon, Hong Kong.
 香港九龍新填地街 352 號地下
 Tel: 2385 2644, 2780 7505 Fax: 2771 4599
 url: <http://www.ckcanvasltd.com> email: contact@ckcanvasltd.com



Acoustics Innovation

SilentUP® Retractable Noise Barrier

PATENTED



Product of Hong Kong
**THE WORLD'S FIRST
RETRACTABLE NOISE BARRIER**
27dB(A) NOISE REDUCTION*

* Tested with white noise source with SilentUP® STC24

Happy Valley Race Course



Roadworks

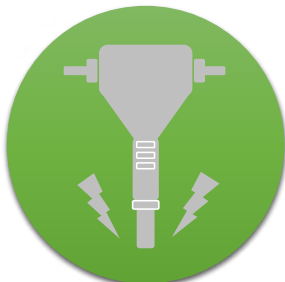

Breaking
Drilling



Piling



Loading
Unloading



Concreting

aihk.hk

info@aihk.hk

(852) 2702-2007

R&D Division of





Acoustics Innovation

SilentUP®

Product Description

SilentUP® is a patented retractable noise barrier for construction works and outdoor music events. It can be easily installed and mobilized by people without using any machines. No concrete foundation is required and the installation process is quiet enough to be conducted even at night time. The panels are installed upwards from ground level and connected by magnetic gap sealing.

Our product has been widely used in Hong Kong. Visit our website for the job references aihk.hk/SilentUP/reference.

Benefits

- ▶ Minimize noise complaints
- ▶ Quiet and manual installation
- ▶ No concrete foundation required
- ▶ Flexible construction site planning
- ▶ Facilitate Construction Noise Permit (CNP) application process

Technical Information

SilentUP® noise barrier material conforms to the flammability requirement specifications.

BS5867-2:2008 TYPE B
GF8624

Product Specification

STC	18	24
Insertion Loss*	22 dB(A)	27 dB(A)
Modular Weight	5kg	8kg
Maximum Height	7m	5m
Modular Size	1m(H) x1.35m(W)	
Standard Colour	Grey	
Panel Thickness	100mm on edges	

* Tested with white noise source



CITF 建造業
創科基金

CITF Pre-approved Product

Eligible contractors can apply for CITF.

citf.cic.hk

Installation videos available at aihk.hk/youtube

aihk.hk

info@aihk.hk

(852) 2702-2007

R&D Division of



Care has been taken to ensure the provided information is accurate, but Acoustics Innovation Ltd, does not accept responsibility or liability for errors or information which is found to be misleading.



Client Feedback

“Some of our contractors have used the retractable noise barriers to facilitate CNP application. They have found this innovative product useful - lightweight, easy to manoeuvre, and fit for purpose.”

Richard Kwan
Former Environment Manager
MTR Corporation Ltd

“We are impressed by SilentUP’s quick installation and relocation, it is definitely one of the best innovations and practicable “ approaches for the noise mitigation measures for the construction activities. ”

Lighting Chan
Environmental Compliance Support Manager,
Leighton Asia Ltd

“We are happy with Acoustics Innovation’s professional service (SilentUP Noise Barrier) in helping us achieve our noise mitigation goals.”

Ronald Fung
Project QA & Environmental Manager
Kier - Laing O’Rourke - Kaden Joint Venture

“SilentUP is definitely a useful tool to minimize the noise pollution. We successfully obtained a CNP and most importantly no complaint has been received from the NSRs.”

Clarence Yeung
Environmental Officer
Chun Wo Construction and Engineering Co. Ltd

REPORT TO: Acoustics Innovation Limited

ADDRESS: Unit 106, 1/F, Block A, Shatin Industrial Centre
5-7 Yuen Shun Circuit
Shatin, N.T., H.K.

ATTN.: Mr. Max Yiu

REPORT NO.: APJ16-034-RP001(STC)

ISSUE DATE: 3 February 2017

**HOKLAS Accredited Laboratory
Sound Transmission Loss Measurement
Test Report
for
SilentUP[®] Retractable Noise Barrier**

(PROJECT NO.: APJ16-034)

HKAS has accredited this Laboratory (Reg. No. HOKLAS 122) under HOKLAS for specific laboratory activities as listed in the HOKLAS directory of accredited laboratories.

The report shall only be reproduced in FULL unless prior written approval is obtained from Acoustics and Air Testing Laboratory Co. Ltd.

APJ16-034-RP001(STC)

Page 1 of 9

1. Method of Measurement

- 1.1 The measurement was carried out in accordance with ASTM E90-09 "Laboratory Measurement of Airborne Sound Transmission Loss of Building Partitions" in the reverberation room of Acoustics and Air Testing Laboratory Co. Ltd. And the single number rating of airborne sound transmission loss is given as Sound Transmission Class (STC) by evaluated in accordance with ASTM E413-10 "Classification for Rating Sound Insulation".

2. Details of Measurement**2.1 Principle of Measurement**

The sound transmission loss is usually measured in a laboratory by placing the element in an opening between two adjacent reverberant rooms designed for such tests. Noise is introduced into one of the rooms, referred to as the source room, and part of the sound energy is transmitted through the test element into the second room, referred to as the receiving room. The resulting mean space-average sound pressure levels in the source and receiving rooms are denoted by L_1 and L_2 respectively.

The sound transmission loss is given by

$$TL = L_1 - L_2 + 10 \log(S/A)$$

Where

- L_1 is the average sound pressure level in the source room, in dB;
 L_2 is the average sound pressure level in the receiving room, in dB;
 S is the area of the test specimen, in m^2 ;
 A is the equivalent absorption area in the receiving room, in meters sabins.

$$A = (0.9210Vd/c)$$

Where

- V is the receiving room volume, in m^3 ;
 d is the rate of decay of sound pressure level in receiving room, dB/s;
 c is the speed of sound in the medium, m/s.

The speed of sound changes with temperature and is shall be calculated for the conditions existing at the time of test from the equation:

$$c = 20.047 \sqrt{273.15 + t}$$

Where

- t is the receiving room temperature, measured to nearest degree.

HKAS has accredited this Laboratory (Reg. No. HOKLAS 122) under HOKLAS for specific laboratory activities as listed in the HOKLAS directory of accredited laboratories.

The report shall only be reproduced in FULL unless prior written approval is obtained from Acoustics and Air Testing Laboratory Co. Ltd.

APJ16-034-RP001(STC)

Page 2 of 9

The Sound Transmission Class (STC) of test specimen is calculated by comparing the sixteen values of Sound Transmission Loss from 125 Hz to 4000 Hz with a defined reference curve which is incremented until the requirements of ASTM E 413-10 are met.

2.2 Laboratory Location

Fo Tan Main Laboratory -
Room 422, Leader Industrial Centre, 57-59 Au Pui Wan Street,
Fo Tan, Shatin, N.T., Hong Kong.

2.3 Test Condition

Conditions	Source room	Receiving room
Volume	84m ³	203m ³
Air Temperature	22.0°C	21.6°C
Relative Humidity	51.0%	52.5%

2.4 Test Date

Date of receipt of test item: 25 January 2017

Dates of commencement and completion of test

Commencement date: 2 February 2017

Completion date: 2 February 2017

2.5 Instrumentation

2.5.1 For sound production

Type	Serial No.
One Real Time Frequency Analyzer – LAN-XI 3160A	3160-100361
One Equalizer – Marantz EQ20D	56E040097
One Amplifier – B&K 2716 Power Amplifier	2571771
One OmniPower Sound Source – Bruel & Kjaer 4296	2128136
One Loudspeaker – JBL EON 515 Loudspeaker	VTP0890-14112

2.5.2 For sound measurement

One Real Time Frequency Analyzer – LAN-XI 3160A	3160-100361
Two Free-field ½" Microphone – Bruel & Kjaer 4190	2731708 & 2731709
Two ½" Microphone Preamplifier – Bruel & Kjaer 2669	2081972 & 2081971
One Sound Level Calibrator – Bruel & Kjaer 4231	1914426

2.5.3 For reverberation time measurement

One Real Time Frequency Analyzer – LAN-XI 3160A	3160-100361
One Free-field ½" Microphone – Bruel & Kjaer 4190	2731708
One ½" Microphone Preamplifier – Bruel & Kjaer 2669	2081972

HKAS has accredited this Laboratory (Reg. No. HOKLAS 122) under HOKLAS for specific laboratory activities as listed in the HOKLAS directory of accredited laboratories.

The report shall only be reproduced in FULL unless prior written approval is obtained from Acoustics and Air Testing Laboratory Co. Ltd.

APJ16-034-RP001(STC)

Page 3 of 9



3. Results Application

- 3.1 The results obtained can be used to design building elements with appropriate acoustic properties, to compare the sound insulation properties of building elements and to classify such elements according to their sound insulation capabilities.
- 3.2 The measurements are performed in laboratory test facilities in which transmission of sound on flanking paths is suppressed. Results of measurements shall not be applied directly in the field without accounting for other factors affecting sound insulation, especially flanking transmission and loss factor.
- 3.3 The obtained test results relate only to the tested specimen.

4. Description of the Test Construction

- 4.1 Specimen description: The test specimen composed of 2 layers of 40mm thick acoustics absorptive infill (0.5kg/m^2) sandwiched by 2 layers of 0.55kg/m^2 acoustic mat (0.9mm thick) with ~100mm separation.
- 4.2 The system was essentially as detailed in the client supplied drawing reproduced as in Appendix 1. Only the physical dimensions of the system were verified by the laboratory.
- 4.3 Overall specimen size: 3000 mm (wide) X 3450 mm (high) X ~100 mm (thick).
- 4.4 The tested noise barrier system was supplied and installed by Acoustics Innovation Limited
- 4.5 Photographic records showing the test specimen and measurement setup are given in Appendix 2.

HKAS has accredited this Laboratory (Reg. No. HOKLAS 122) under HOKLAS for specific laboratory activities as listed in the HOKLAS directory of accredited laboratories.

The report shall only be reproduced in FULL unless prior written approval is obtained from Acoustics and Air Testing Laboratory Co. Ltd.

APJ16-034-RP001(STC)

Page 4 of 9

**5. Measurement Results**

5.1 The results of measurement for the tested specimen are given in the following table:

Frequency f, Hz	Sound Transmission loss, dB	Sound Transmission loss, dB	Uncertainty, dB
100	2	5	± 1.64
125	6		± 1.20
160	8		± 0.90
200	7	7	± 1.21
250	7		± 1.07
315	7		± 0.74
400	9	11	± 0.68
500	12		± 0.56
630	15		± 0.45
800	20	22	± 0.41
1000	23		± 0.36
1250	26		± 0.32
1600	28	30	± 0.29
2000	31		± 0.34
2500	32		± 0.27
3150	33	34	± 0.29
4000	34		± 0.31
5000	35		± 0.33

5.2 The measured sound transmission loss of the tested specimen against 1/3-octave band center frequencies is plotted on Figure 1.

5.3 The 95% confidence interval is calculated according to the method stated in the Standard ASTM E90-09 A2.

HKAS has accredited this Laboratory (Reg. No. HOKLAS 122) under HOKLAS for specific laboratory activities as listed in the HOKLAS directory of accredited laboratories.

The report shall only be reproduced in FULL unless prior written approval is obtained from Acoustics and Air Testing Laboratory Co. Ltd.

APJ16-034-RP001(STC)

Page 5 of 9

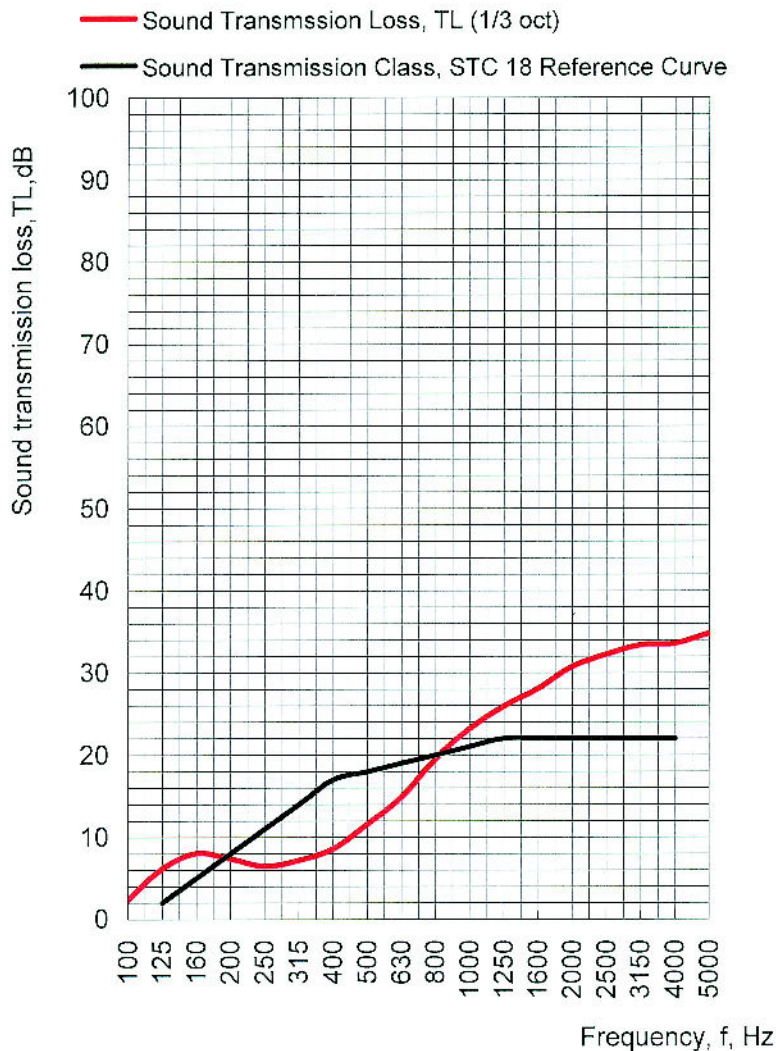

Figure 1. Sound transmission loss against Frequency

5.4 The single number rating of sound transmission class (STC) In accordance with ASTM E413-10 of the tested specimen is given below:

Description	Sound Transmission Class, STC
SilentUP® Retractable Noise Barrier	STC 18

Prepared by: 
Tang Cheuk Hang
 Quality Manager
 WN / MT / KW / JL

Endorsed by: 
Ng Yan Wa
 Laboratory Manager
 (Approved Signatory)

- END -

HKAS has accredited this Laboratory (Reg. No. HOKLAS 122) under HOKLAS for specific laboratory activities as listed in the HOKLAS directory of accredited laboratories.
 The report shall only be reproduced in FULL unless prior written approval is obtained from Acoustics and Air Testing Laboratory Co. Ltd.
 APJ16-034-RP001(STC) Page 6 of 9



Appendix List

- | | |
|-------------------|--|
| Appendix 1 | Details of Test Specimen
(Drawing supplied by the Client) |
| Appendix 2 | Photographic Records |

HKAS has accredited this Laboratory (Reg. No. HOKLAS 122) under HOKLAS for specific laboratory activities as listed in the HOKLAS directory of accredited laboratories.

The report shall only be reproduced in FULL unless prior written approval is obtained from Acoustics and Air Testing Laboratory Co. Ltd.

APJ16-034-RP001(STC)

Page 7 of 9

Appendix 1

Details of Test Specimen (Drawing supplied by the Client)

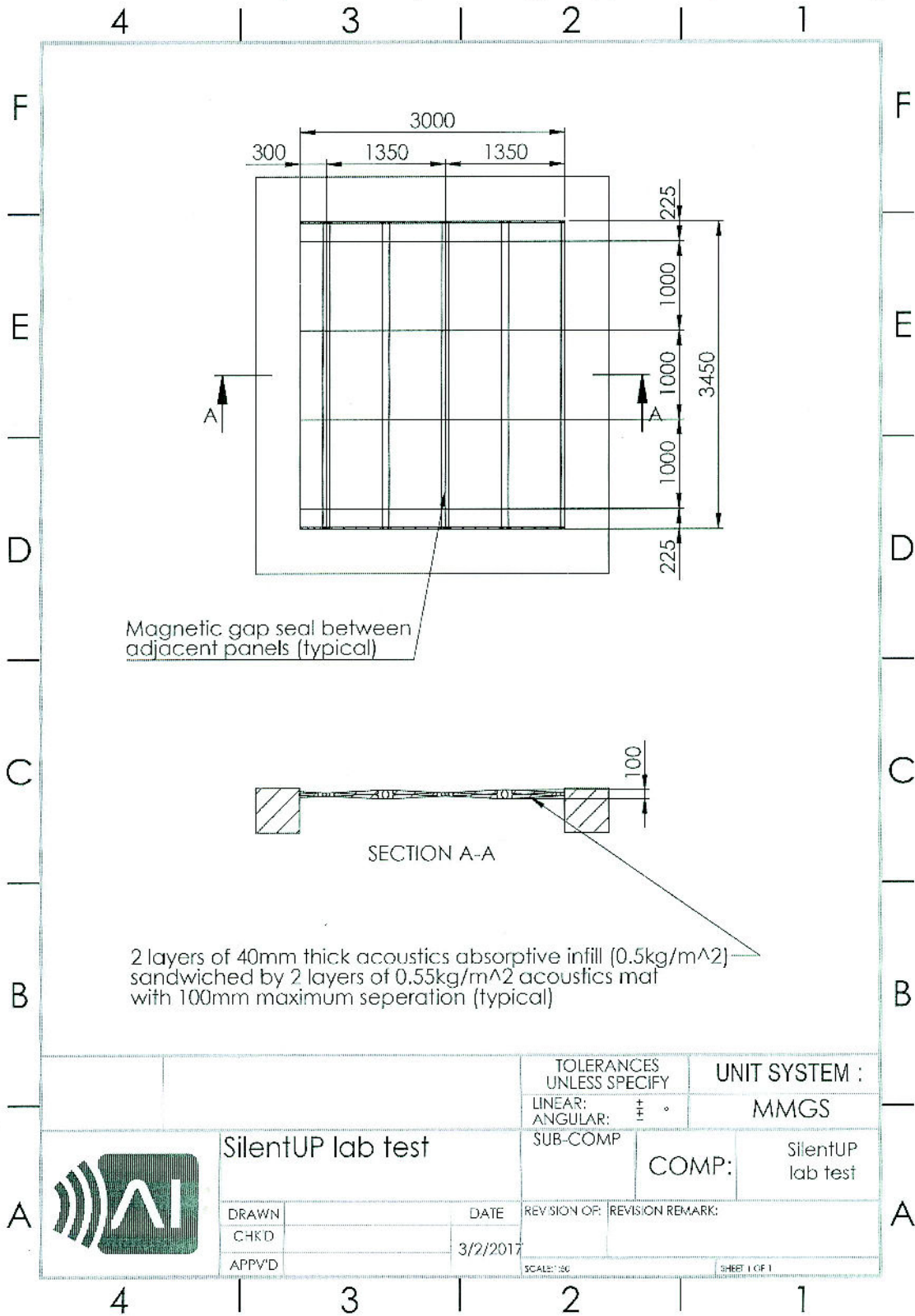

HKAS has accredited this Laboratory (Reg. No. HOKLAS 122) under HOKLAS for specific laboratory activities as listed in the HOKLAS directory of accredited laboratories.
 The report shall only be reproduced in FULL unless prior written approval is obtained from Acoustics and Air Testing Laboratory Co. Ltd.
 APJ16-034-RP001(STC)



Appendix 2

Photographic Records



Measurement set-up (Source room)



Measurement set-up (Receiving room)

Section View of the Noise Barrier

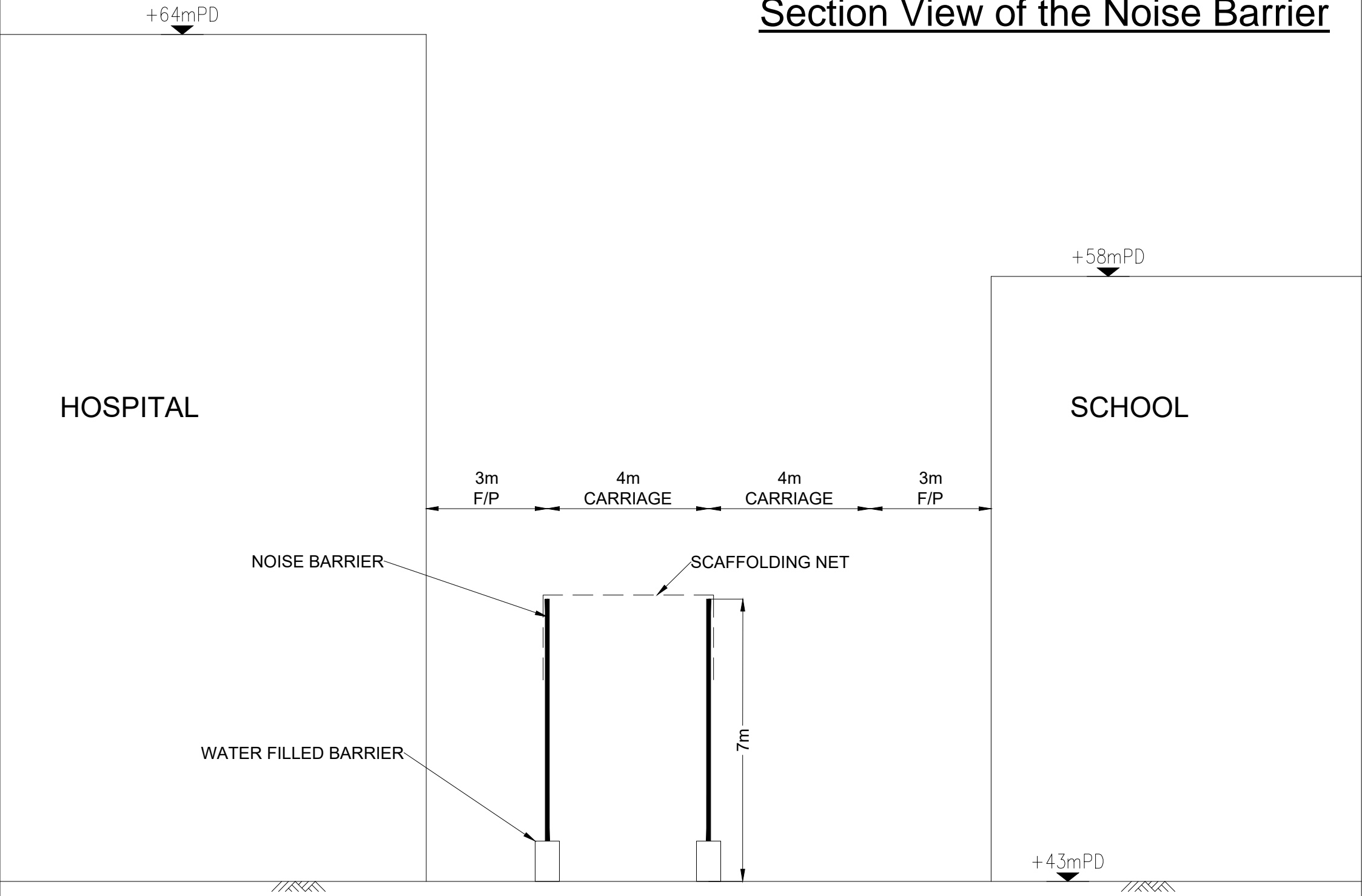

+64mPD

+58mPD

HOSPITAL

SCHOOL

3m
F/P

4m
CARRIAGE

4m
CARRIAGE

3m
F/P

NOISE BARRIER

SCAFFOLDING NET

WATER FILLED BARRIER

7m

+43mPD

Contract No. 21/WSD/21

Relocation of Diamond Hill Fresh Water and Salt Water Reservoirs to Caverns

Appendix E – Implementation Schedule of Proposed Mitigation Measures

Implementation Schedule of Mitigation Measures

CNMP/ EIA Ref.	Proposed Mitigation Measures	Target PME	Implemented by	Location	Period	Requirements or Standard to be achieved
EIA S4.8.1	The contractor should limit the pipe section to be constructed by open cut method in a length of no more than 30 m at any one time when works are in close proximity to NSRs. Each work front along the proposed watermain laying should be separated by a clearance distance of at least 60 m.	All PME to be operated for watermain laying works	Main Contractor	All construction area for watermain laying works	Apr 2023 – Oct 2027	TM-EIAO
Paragraph 2, S3.2 of CNMP	The use of noise barrier for certain PME could generally provide a 5 dB(A) reduction for movable PME and 10 dB(A) for stationary PME. The barrier material shall have a superficial surface density of not less than 10 kg/m ² and have no opening or gaps. Sound-absorbent lining inside the enclosure should be at least 25 mm thick.	Asphalt paver, excavator etc.	Main Contractor	All areas of the Project	Apr 2023 – Oct 2027	Annex 5, TM-EIAO
Paragraph 2, S3.2 of CNMP	Noise enclosure lined with absorptive materials shall be provided at the tunnel portal to mitigate the noise from tunnel/cavern construction. The enclosure is a gap free enclosure with acoustic doors for vehicular access purpose. The acoustic doors shall remain closed throughout the construction period. The sheet material mass of the noise enclosure should be at least 10 kg/m ² and sound-absorbent lining inside the enclosure should be at least 25 mm thick.	All PME to be operated within the cavern	Main Contractor	Tunnel Portal	Apr 2023 – Oct 2027	<ul style="list-style-type: none"> • EIAO-TM • A Practical Guide for the Reduction of Noise from Construction Works
EIA S4.8.4	Provision of movable noise barriers of 3m or above in	Refer to table 4.1	Main	All areas of	Apr 2023 –	TM-EIAO

CNMP/ EIA Ref.	Proposed Mitigation Measures	Target PME	Implemented by	Location	Period	Requirements or Standard to be achieved
	height and with a short-cantilevered section on the top with skid footing should be used and located within a few metres of stationary plant and mobile plant such that the line of sight to the NSR is blocked by the barriers.		Contractor	the Project	Oct 2027	
EIA S4.8.4	Noise barrier/enclosure should be inspected and maintained regularly. The contractor should design and provide details of the temporary noise barriers and noise enclosure to the Engineer for approval.	Asphalt paver, excavator etc.	Main Contractor	All areas of the Project	Apr 2023 – Oct 2027	TM-EIAO
EIA S 4.8.9	<p>Good Site Management Practices</p> <ul style="list-style-type: none"> • Only well-maintained plant should be operated on-site and plant will be serviced regularly during the construction phase; • Silencers or mufflers on construction equipment should be utilized and should be properly maintained during the construction phase; • Mobile plant, if any, should be sited away from NSRs; • Machines and plant (such as trucks) that may be in intermittent use should be shut down between work periods or will be throttled down to a minimum; • Plant known to emit noise strongly in one direction should be orientated so that the noise is directed away from the nearby NSRs; • Material stockpiles and other structures should be 	All PME	Main Contractor	All areas of the Project	Apr 2023 – Oct 2027	Annex 5, TM-EIAO

CNMP/ EIA Ref.	Proposed Mitigation Measures	Target PME	Implemented by	Location	Period	Requirements or Standard to be achieved
	<p>effectively utilised in screening noise from on-site construction activities;</p> <ul style="list-style-type: none"> • The contractor should devise, arrange methods of working and carrying out the works in such manner as to minimise noise impacts on the surrounding environment, and should provide experience personnel with suitable training to ensure that all these measures are implemented properly; and; • The contractor should minimise construction noise exposure to the school (especially during examination periods) as much as possible. The contractor should liaise with the school and Examination Authority to ascertain the exact dates and times of all examination periods during the course of the contract and to avoid noisy activities during these periods 					
EIA S 4.8.9	<p>Use of quiet PME is considered to be a practicable means to mitigate the construction noise impact. Quiet plant is defined as a PME having actual SWL lower than the value specified in the GW-TM.</p>	Refer to table 2.2	Main Contractor	All areas of the Project	Apr 2023 – Oct 2027	Annex 5, TM-EIAO

Contract No. 21/WSD/21

Relocation of Diamond Hill Fresh Water and Salt Water Reservoirs to Caverns

Appendix F – Concrete Lorry Mixer Sound Power Level Measurement Report

Sound Power Level Measurement Report for EURO V Concrete Lorry Mixer (VR9537)

C221016W-01-A

PREPARED BY



Eddy Ng
*BSc(Hons), MHKIOA, MIOA, MMOIA, MIET,
MAES, MASHRAE, MHKIEIA, REnv, BEAM Pro*

APPROVED BY



Banting Wong
*MSc, CEng, MIOA,
MHKIOA, AFCHKRI, MHKIEIA, MHKIQEP*

28 October 2022

NOVOX Limited

Tel: (852) 2690 9881 | Fax: (852) 2690 9798 | www.novox.com.hk
Room L, 7/F, Block 2, Kinho Industrial Building, 14-24 Au Pui Wan Street, Fotan Shatin

Contents

	Pages
1. Measurement Information	3
2. Sound Source	3
3. Instrumentation	5
4. Noise Measurement Methodology	5
4.1. Measurement Standard and Determination of SWL.....	5
4.2. Measurement Conditions	5
4.3. Microphone Locations	6
5. Measurement Results	7
6. Conclusions.....	8
Appendix A. Catalog of the Sound Source under Test	9
Appendix B. Calibration Certificates	11
Appendix C. Measurement Photos	18
Appendix D. Expanded Measurement Uncertainty	20

1. Measurement Information

Date and Time	27 October 2022, 1615 to 1700 hrs
Personnel	SWL measurement was conducted by CY Chan (MHKIOA: M238), Ting Cai (MHKIOA: M346) and Lyn Lin (MHKIOA: M368)
Site	Construction Site of District Open Space, Sports Centre cum Public Vehicle Park at Sze Mei Street
Standard	ISO 3746:2010 Acoustics - Determination of sound power levels of noise sources using sound pressure - Survey method using an enveloping measurement surface over a reflecting plane
Machine Type	EURO V Concrete Lorry Mixer (VR9537)
Manufacturer	HINO
Model	FY1ATRM-AAG

2. Sound Source

The sound source is one unit of HINO EURO V Concrete Lorry Mixer (VR9537) with exhaust gas recirculation (EGR) (**Figure 2.1 & Appendix A**). The major noise source of the machine is from the engine unit and mixer drum unit while operation.

The overall dimension of the measurement reference box is 8.6m (L) X 2.5m (W) X 3.6m (H). The Concrete Lorry Mixer was tested of two operation modes, which are

- Travelling at 5 kph (which is construction site limit) on flat ground with full load of concrete and mixer drum rotating at normal speed up to 7 rpm; and
- Concrete discharge with mixer drum rotating at normal speed of 10 rpm.

Figure 2.1: HINO EURO V Concrete Lorry Mixer (VR9537)



3. Instrumentation

Two units of sound level meter and one unit of acoustic calibrator were employed for the noise measurement. The instrumentations were listed in **Table 3.1** provided below.

Table 3.1: Measurement Instrumentation

Equipment	Brand	Model	Serial No.	Expiry Date
Sound Level Meter	Svantek	SVAN958A	69037	07 Apr 2023
Sound Level Meter	Svantek	SVAN977	34883	25 Apr 2023
Acoustic Calibrator	Svantek	SV35A	90243	07 Apr 2023

Field calibrations by means of a standard handheld acoustic calibrator generating a known noise level were conducted before and after measurements. This is to confirm that there was no significant shift on the sensitivity of the SLM at the calibration level and frequency. The SLM and the calibrator are maintained with regular laboratory calibration (IEC 61260 and IEC 60942). Sound level meter, microphone and pre-amplifier were considered as a set of instrumentation for laboratory calibration. The equipment calibration certificates are given in **Appendix B**.

4. Noise Measurement Methodology

4.1. Measurement Standard and Determination of SWL

The measurement was conducted in accordance with *ISO 3746:2010 Acoustics - Determination of sound power levels of noise sources using sound pressure - Survey method using an enveloping measurement surface over a reflecting plane*.

The Sound Power Level (SWL) was determined by summation of its Sound Pressure Level (SPL) and its area correction (AC).

$$SWL = SPL_{\text{average}} + AC - K_{1A} - K_{2A}$$

Where in,

- SPL_{average}: Energy average of measured Sound Pressure Level
- AC: Area correction = 10 log (Measurement Surface Area)
- K_{1A}: Corrections for Background Noise
- K_{2A}: Environmental Correction

4.2. Measurement Conditions

The SPL measurement was conducted on an open area. The EURO V Concrete Lorry Mixer (VR9537) was placed on flat and horizontal hard reflecting surface. Environmental correction due to reverberation was neglected for conservativeness.

4.3. Microphone Locations

SPL measurement was conducted with a parallelepiped measurement surface. The measurement distance was 2.5m from the reference box and measurement was conducted at 8 nos points. $L_{Aeq,15s}$ was measured at each measurement point, as illustrated in **Figure 4.1** to **Figure 4.2**. The measurement photos are shown in **Appendix C**.

Figure 4.1: Microphone Location (Top View)

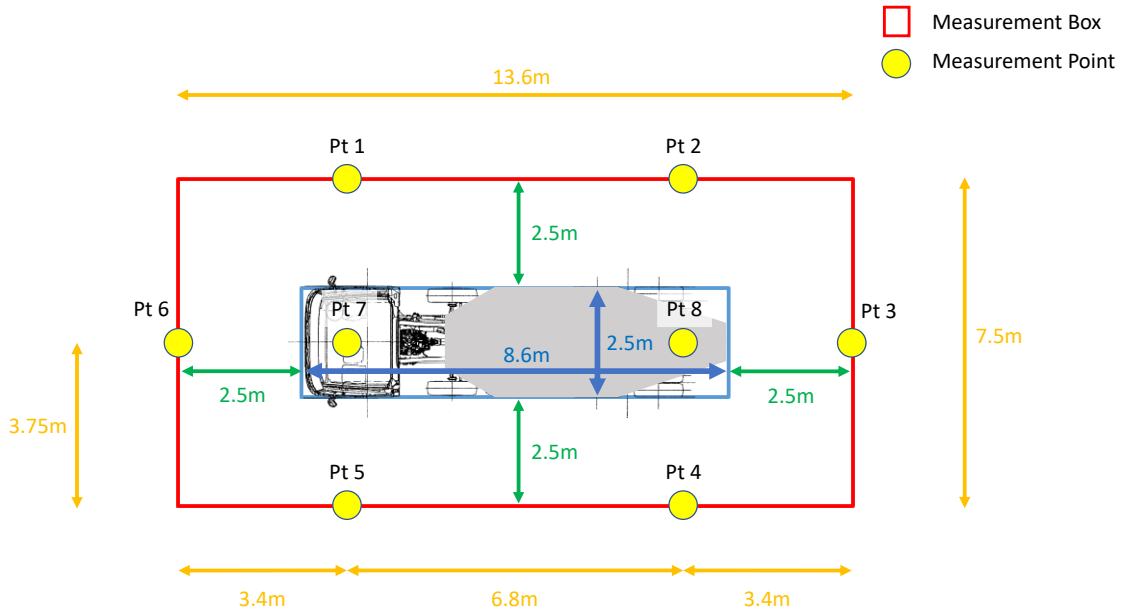
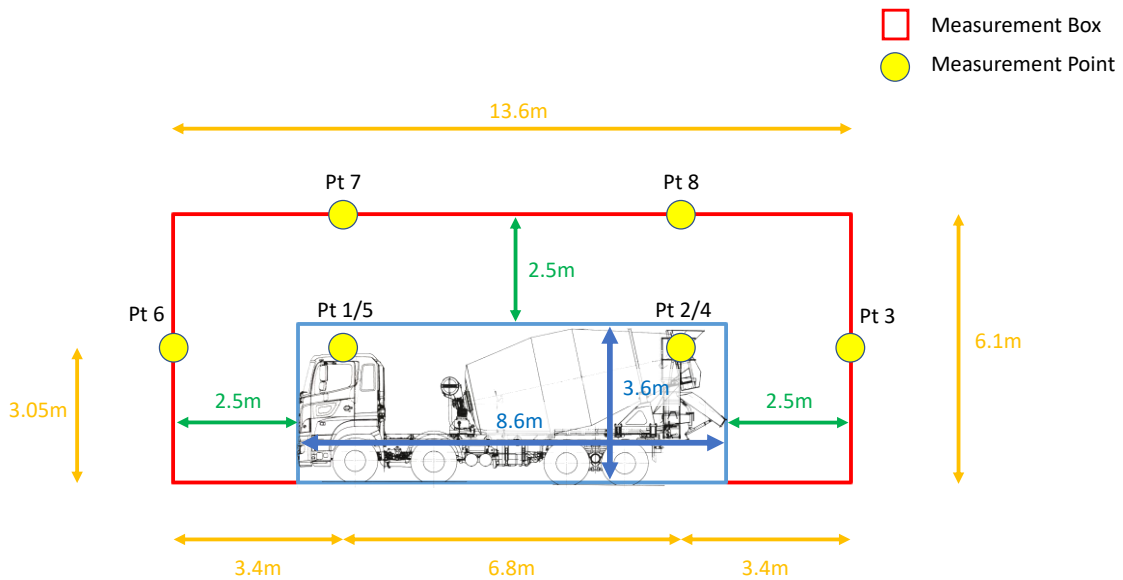

Figure 4.2: Microphone Location (Side View)



5. Measurement Results

The $L_{Aeq,15s}$ time-averaged sound pressure level (SPL) of the corresponding points and calculated sound power level are listed in **Table 5.1** and **Table 5.2**. The expanded measurement uncertainty is shown in **Appendix D**.

Table 5.1: SWL Measurement Results - Travelling Mode

Area Correction				
Dimensions of Reference Box, m		Dimensions of Measurement Box, m		
-	-	Measurement Distance, d	2.5	
Length, l_1	8.6	$a = 0.5l_1 + d$	6.8	
Width, l_2	2.5	$b = 0.5l_2 + d$	3.8	
Height, l_3	3.6	$c = l_3 + d$	6.1	
Measurement Surface Area, $S = 4(ab+bc+ca)$, m^2			359.4	
Area Correction, $AC = 10\log(S)$, dB			25.6	
Measured Noise Level in $L_{Aeq,30s}$, dB(A) (Travelling Mode)				
Point	Location Description	$L_{Aeq,30s}$	B/G	Remark
1	Right Side	76.6	62.3	
2		75.7	61.4	
3	Back Side	71.7	62.0	
4	Left Side	73.2	62.8	
5		75.2	62.9	
6	Front Side	73.0	62.4	
7	Top Side	72.8	62.7	
8		71.0	62.7	
Averaged $L_{Aeq,30s}$:				74.0
Average B/G :				62.4
Average B/G Corrected Noise Level, L_{pA} :				73.7
Sound Power Level, $SWL = L_{pA} + AC - K_{2A}$, dB(A)				99.3

Table 5.2: SWL Measurement Results – Concrete Discharge Mode

Area Correction				
Dimensions of Reference Box, m		Dimensions of Measurement Box, m		
-	-	Measurement Distance, d	2.5	
Length, l_1	8.6	$a = 0.5l_1 + d$	6.8	
Width, l_2	2.5	$b = 0.5l_2 + d$	3.8	
Height, l_3	3.6	$c = l_3 + d$	6.1	
Measurement Surface Area, $S = 4(ab+bc+ca)$, m^2				359.4
Area Correction, $AC = 10\log(S)$, dB				25.6
Measured Noise Level in $L_{Aeq,30s}$, $dB(A)$ (Concrete Discharge Mode)				
Point	Location Description	$L_{Aeq,30s}$	B/G	Remark
1	Right Side	78.1	59.7	
2		79.0	61.0	
3	Back Side	77.9	61.5	
4	Left Side	78.9	60.4	
5		75.6	60.3	
6	Front Side	75.9	61.4	
7	Top Side	77.9	60.4	
8		77.0	59.6	
Averaged $L_{Aeq,30s}$:				77.7
Average B/G :				60.6
Average B/G Corrected Noise Level, L_{pA} :				77.6
Sound Power Level, $SWL = L_{pA} + AC - K_{2A}$, $dB(A)$				103.2

6. Conclusions

Sound power level (SWL) measurement was conducted in accordance with ISO 3746:2010 for HINO EURO V Concrete Lorry Mixer (VR9537). The measured SWL is determined to be **103dB(A)** for worst-case scenario as a conservative approach.

Appendix A. Catalog of the Sound Source under Test



30 噸混凝土車

No.1 700系列
30噸混凝土車最高銷量

Yuen Long Terminal HINO

8m³ 田螺王
行業之霸

引擎型號：A09C 總容積：8,866c.c.

FS 30 噸 田螺車陣

350PS/1,800rpm
145kgf.m/1,100-1,600rpm

R 2 4 6 8
1 1 1 1
1 3 5 7 9
9MT

全平陣面輕量車陣 **X** V-Rod 連桿設計

輕量化的全平陣面令裝斗方便快捷，堅固穩妥，載重更多。高穩定後軸懸掛系統配備 V-Rod 連桿及雙油壓吸震筒，令田螺運作更穩定、更安全。

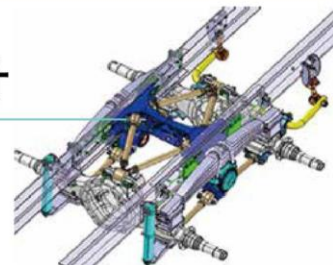

規格

24/30 噸泥車

30 噸混凝土車

Emission Standard 廢氣排放標準		EURO V 環保五型		EURO V 環保五型
Model 型號		FS1ELRD-KAG 泥車陣	FY1ETRD-KAG 泥車陣	FY1ATRM-AAG
G.V.W. 總重量 (kg 公斤)		24,000	30,000	30,000
Axle Capacity 車軸載重量	1st Axle 第一軸 (kg 公斤)	7,100	7,100	-
	2nd Axle 第二軸 (kg 公斤)	9,000	7,100	-
	3rd Axle 第三軸 (kg 公斤)	9,000	9,000	-
	4th Axle 第四軸 (kg 公斤)	-	9,000	-
	Front 前軸 (kg 公斤)	-	-	6,300 + 6,300
	Rear 後軸 (kg 公斤)	-	-	9,000 + 9,000
Dimensions 車身尺寸	Overall Length 總長度 OL (mm 毫米)	7,695	8,895	8,595
	Overall Height 總高度 OH (mm 毫米)	3,030	3,065	3,055
	Cab Width 駕駛室闊度 CW (mm 毫米)	2,490	2,490	2,490
	Wheelbase 軸距 WB (mm 毫米)	3,630 + 1,350	1,850 + 3,130 + 1,350	1,850 + 3,130 + 1,350
	Cab to Rear Axle 駕駛室後至後軸 CA (mm 毫米)	3,595	4,945	4,950
	Rear Overhang 尾懸出量 ROH (mm 毫米)	1,960	1,810	1,560
	Chassis Frame Height 陣尾高度 FH (mm 毫米)	1,125	1,125	-
	Rear Axle Width 後軸闊度 RW (mm 毫米)	2,450	2,450	2,450
Engine 引擎	Model 型號	E13C-WA		A09C UE
	Type 類別	Diesel Engine, In-line 6 Cylinders, Variable Geometry Turbocharger (VGT) and Intercooler, Exhaust Gas Recirculation (EGR) System, SCR After-treatment System 柴油引擎，直列式六汽缸，可變活瓣渦輪增壓器連中置冷卻器，廢氣再循環系統，SCR 後處理減排系統		Diesel Engine, In-line 6 Cylinders, Variable Geometry Turbo (VGT) Charger and Intercooler, Exhaust Gas Recirculation (EGR) & Diesel Particulate Filter (DPF) 柴油引擎，直列式六汽缸，可變活瓣渦輪增壓器連中置冷卻器，廢氣再循環及柴油微粒淨化系統
	Capacity 汽缸容積 (cc 毫升)	12,913		8,866
	Max. Output 最大馬力 (JIS) (PS/rpm 匹/轉)	410 / 1,800		350 / 1,800
Transmission 傳動系統	Max. Torque 最大扭力 (JIS) (kgf.m/rpm 公斤-米/轉)	195 / 1,100		145 / 1,100 - 1,600
	Type 類別	7 Forward & 1 Reverse Speeds, Synchromeshed 2nd-7th Gears 七前速及一後速，二至七波同步齒合式		9 Forward & 1 Reverse Speeds, Full Synchromeshed 1st-9th Gears 九前速及一後速，同步齒合式
	Gear Ratio 齒輪比例	6.230 - 0.595		10.178 - 0.724
Brake System 制動系統	Rear Axle Gear Ratio 尾牙比例	6.428		5.428
	Service Brake 行車制動	Full Air, Dual Circuit, Wedge Type, Leading & Trailing Shoes for Front & Rear with Auto Brake Shoe Adjuster, ABS 雙迴路全風模式制動，配合領從式制動蹄片及煞車皮虛位自動調校器，ABS 防鎖煞車系統		Full Air, Dual Circuit, Auto Brake Shoes Adjuster, ABS 雙迴路全風制動，煞車皮虛位自動調校器，ABS 防鎖煞車系統
	Parking Brake 泊車制動	Spring Brake on 1st & 2nd Axle Wheels 彈簧制動第一軸及第二軸	Spring Brake on 3rd & 4th Axle Wheels 彈簧制動第三軸及第四軸	Spring Brake, Acting on Rear Wheels 彈簧制動尾輪
Suspension 懸掛系統	Auxiliary Brake 輔助制動	Easy Smooth Start (ESS) System, Engine Retarder ESS 制動系統，引擎制動		1. Exhaust Brake 廢氣制動 2. Engine retarder 引擎制動系統
	Front 前軸	Long Tapered Leaf Springs with Shock Absorbers and Stabilizer 龍船葉片式彈簧附吸震筒及穩定桿		Long Tapered Parabolic-Leaf Springs with Shock Absorbers 龍船葉片式彈簧片附吸震筒
Performance 性能	Rear 後軸	Semi-Elliptic Leaf Springs with Torque Rods 半橢圓彈簧片連扭力桿		Long Tapered Parabolic-Leaf Springs with Shock Absorbers 龍船葉片式彈簧片附吸震筒
	Max. Speed 最高時速 (km/h 公里 / 小時)	110	110	-
Tire 輪胎	Gradeability at G.V.W. 爬坡角度 (tan θ)	60.0%	50.4%	-
	Fuel Tank Capacity 油缸容量 (L 公升)	12R22.5		11R22.5 148/145 Alloy Wheel 合金鈴
Standard Equipment 標準裝置	• ISRI Auto Adjustable Air Suspension Driver Seat ISRI 自動調節氣墊避震司機座椅			
	• Transmission P.T.O. 波箱動力輸出器			
	• SCR After-treatment System SCR 後處理減排系統			
	• Headlamp with Washer 頭燈連清洗裝置			
	• Remote Control & Heater Mirrors 電動調校及發熱線後視鏡		• 24V-60A Alternator 24 伏特 - 60 安培發電機	
	• Electrical Tilttable Air Suspension Driver Cab 電動起揚式氣墊避震全浮動駕駛室		• Factory Installed Air-Conditioner (R134A) 原廠安裝 R134A 環保冷暖氣系統	
	• 150Ah Batteries 150 安培小時電池		• Spoiler Type Front Bumper 擾流式前車把	
	• Wrap-around Curtain 全包圍式窗簾		• Aluminium Air Tanks 鋁合金風缸	
	• CD Player & AM/FM Radio 鐳射碟機及 AM/FM 收音機		• Energy Absorbing Steering Wheel 吸撞式軚盤	
	• Power Mirror Stay 電動照鏡		• Collapsible Steering Column 縮衝式軚盤柱	
• Power Windows & Central Door Lock 電動車窗及中央門鎖		• Door Side Impact Beam 車門強化防撞桿		
• Power Steering 動力輔助轉向系統				

24/30 噸 泥車尺寸

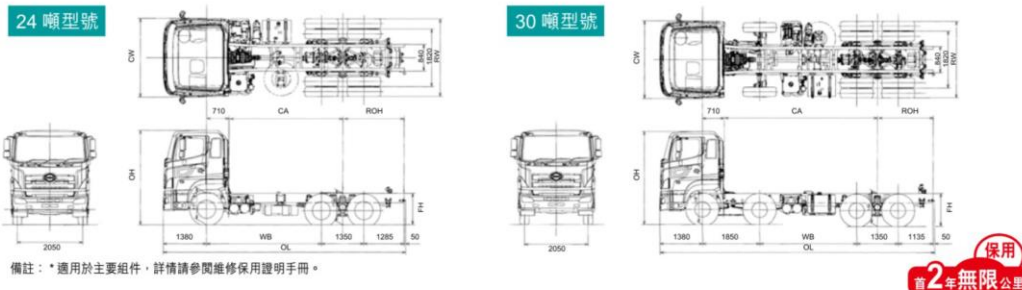

保用
首2年無限公里

Appendix B. Calibration Certificates

Cert. B.1 Sound Level Meter - SVAN958A (SN: 69037)



Certificate of Calibration

Certificate No. ATS22-025-CC001

Customer: Novox Limited
Room L, 7/F, Block 2, Kinho Industrial Building,
14-24 Au Pui Wan Street, Fotan,
Shatin, N.T., Hong Kong

Unit-under-test (UUT):

Description:	Sound Analyzer	, Microphone	, Pre-amplifier
Manufacturer:	Svantek	, PCB	, PCB
Type No.:	SVAN 958A	, 377B02	, 426E01
Serial No.:	69037	, 305696	, 053414

Conditions during calibration:

Temperature:	25°C
Relative Humidity:	60%

Test Specifications: Calibration Check

Date of calibration: 08th April 2022

Test Results: All calibration points are within manufacturer's specification.

Certified by:

Mr. Y. T. Leung / Technical Manager
MIOA, MHKIOA, MHKIQEP



Issue Date: 09th April 2022

Certificate No.: ATS22-025-CC001

Page 1 of 3



Unit E, 2/F., Century Industrial Centre, 33-35 Au Pui Wan Street, Fo Tan, Shatin, New Territories, Hong Kong
Tel: (852) 2690 9126 Fax: (852) 2690 9125 E-mail: info@ATSL.com.hk http://www.ATSL.com.hk

1. The instrument under test was allowed to stabilize in the laboratory for over 24 hours.

2. Calibration equipment:

Description: Multifunction Acoustical Calibrator
Manufacturer & Type: Brüel & Kjær 4226
Serial No.: 2919264
Last Calibration Date: 20th August 2021
Certificate No.: 2HB21001798-0001

The calibration equipment used for calibration is traceable to National Standards via China Ceprei Laboratory Calibration & Testing Centre.

3. The sensitivity of the microphone has been adjusted by the calibration function of the Sound Analyzer (calibrated as 94.0dB at 1000Hz) before the calibration. And the adjusted sensitivity was recorded.

Adjusted Microphone Sensitivity (mV/Pa)	53.00
---	-------

4. The Sound Analyzer has been calibrated in accordance with the requirements as specified in IEC 61672 Class 1, and vendor specific procedures.

5. The values given in this certification only related to the values measured at the time of the calibration and any uncertainties quoted will not allowance for the equipment long-term drift, variations with environmental changes, vibration and shock during transportation, overloading, mis-handling, or the capability of any other laboratory to repeat the calibration. Acoustic Testing Services Limited shall not be liable for any loss or damage resulting from the use of the equipment.





Unit E, 2/F., Century Industrial Centre, 33-35 Au Pui Wan Street, Fo Tan, Shatin, New Territories, Hong Kong
Tel: (852) 2690 9126 Fax: (852) 2690 9125 E-mail: info@ATSL.com.hk http://www.ATSL.com.hk

6. Calibration Results

Setting of unit-under-test (UUT)				Applied value		UUT Reading, dB	IEC 61672-1 Class 1 Tolerance Limits, dB	Conclusion		
Range, dB	Parameter	Frequency Weighting	Response	Level, dB	Frequency, Hz					
40-120	SPL	A	F	94.00	1000	94.0	± 0.7	PASS		
			S			94.0	± 0.7	PASS		
			I			94.0	± 0.7	PASS		
		C	F			93.9	± 0.7	PASS		
			S			93.9	± 0.7	PASS		
			I			94.0	± 0.7	PASS		
		L	F			93.9	± 0.7	PASS		
			S			93.9	± 0.7	PASS		
			I			94.0	± 0.7	PASS		
		A	F			114.00	1000	114.0	± 0.7	PASS
			S					114.0	± 0.7	PASS
			I					114.0	± 0.7	PASS

All calibration points are within manufacturer's specification.

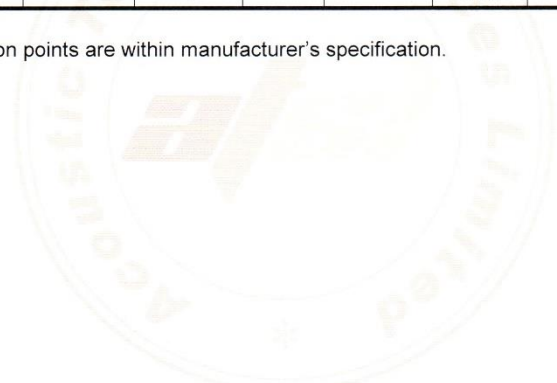

Cert. B.2 Sound Level Meter – SVAN977 (SN: 69037)

CALIBRATION CERTIFICATE



Name of Customer Novox Limited
Address of Customer Room L, 7/F, Block 2, Kinho Industrial Building, 14-24 Au
Pui Wan Street, Fotan, Shatin
Certificate No. SRET-22-CC463

Unit Under Test
Description Sound Level Meter
Manufacturer SVANTEK
Instrument Model SVAN977
Instrument Serial Number 34883

Test Environmental Condition
Laboratory Temperature 25.0°C
Relative Humidity 53.5%
Test Specifications Calibration Check
The instrument under test was allowed to stabilize in the
laboratory for over 24 hours

Calibration Equipment
Description Acoustic Calibrator
Manufacturer 01dB
Model CAL31
Serial No. 89171

1

The test equipment used for calibration is traceable to National Standards. Recommended calibration interval is 12 months from the day of this calibration.

Calibration Results
Calibration data is detailed in the continuation page.

Hong Kong Rhythm Co., Ltd
Shanghai Rhythm Electronic Technology Co., Ltd.
7/F SPA CTR, No.33-35 Lockhart Road, Wan Chai, Hong Kong
Ph.: 2690 9881 | <http://www.rhythm-tech.com>

CNAS Laboratory
Reg. No. L12293 (valid May 2025)
ISO/IEC 17025:2005

CALIBRATION CERTIFICATE



Channel No. and Range, dB	Setting of Unit-under-test (UUT)			Applied Value		UUT Reading, dB	IEC 61672-1 Class 1 Tolerance Limits, dB	Conclusion		
	Parameter	Frequency Weighting	Response	Level, dB	Frequency, Hz					
Ch1 0-130	SPL	A	F	94.00	1000	94.0	±0.7	PASS		
			S			94.0	±0.7	PASS		
			I			94.0	±0.7	PASS		
		C	F			94.0	±0.7	PASS		
			S			94.0	±0.7	PASS		
			I			94.0	±0.7	PASS		
		L	F			94.0	±0.7	PASS		
			S			94.0	±0.7	PASS		
			I			94.0	±0.7	PASS		
		A	F			114.00	1000	113.9	±0.7	PASS
			S					114.0	±0.7	PASS
			I					114.0	±0.7	PASS

This calibration certificate shall not be reproduced except in full, without the written approval of Shanghai Rhythm Electronic Technology Co., Ltd.

2

Prepared and Checked by

K.S. Wong
C.Eng, MHKIQEP

Issue Date: **26 April 2022**

Due Date: **25 April 2023**

Hong Kong Rhythm Co., Ltd
Shanghai Rhythm Electronic Technology Co., Ltd.
7/F SPA CTR, No.33-35 Lockhart Road, Wan Chai, Hong Kong
Ph.: 2690 9881 | <http://www.rhythm-tech.com>

CNAS Laboratory
Reg. No. L12293 (valid May 2025)
ISO/IEC 17025:2005

Cert. B.3 Acoustic Calibrator - SV35A (SN. 90243)



Unit E, 2/F., Century Industrial Centre, 33-35 Au Pui Wan Street, Fo Tan, Shatin, New Territories, Hong Kong
Tel: (852) 2690 9126 Fax: (852) 2690 9125 E-mail: info@ATSL.com.hk http://www.ATSL.com.hk

Certificate of Calibration

Certificate No. ATS22-025-CC002

Customer: **Novox Limited**
Room L, 7/F, Block 2, Kinho Industrial Building,
14-24 Au Pui Wan Street, Fotan,
Shatin, N.T., Hong Kong

Unit-under-test (UUT):

Description: Acoustic Calibrator
Manufacturer: Svantek
Type No.: SV 35A
Serial No.: 90243

Conditions during calibration:

Temperature: 25°C
Relative Humidity: 60%

Test Specifications: Calibration Check

Date of calibration: 08th April 2022

Test Results: All calibration points are within manufacturer's specification.

Certified by:



Mr. Y. T. Leung / Technical Manager
MIOA, MHKIOA, MHKIQEP

Issue Date: 09th April 2022

Certificate No.: ATS22-025-CC002

Page 1 of 2



Unit E, 2/F., Century Industrial Centre, 33-35 Au Pui Wan Street, Fo Tan, Shatin, New Territories, Hong Kong
Tel: (852) 2690 9126 Fax: (852) 2690 9125 E-mail: info@ATSL.com.hk http://www.ATSL.com.hk

1. The instrument under test was allowed to stabilize in the laboratory for over 24 hours.

2. Calibration equipment:

Description:	Sound Analyzer	Reference Microphone
Manufacturer:	Brüel & Kjær	Brüel & Kjær
Type No.:	2270	4189
Serial No.:	3029788	2662797
Last Calibration Date:	24 th August 2021	24 th August 2021
Certificate No.:	AV210161	AV210161

The test equipment used for calibration is traceable to National Standards via Standards and Calibration Laboratory, the Government of the HKSAR.

3. The values given in this certification only related to the values measured at the time of the calibration and any uncertainties quoted will not allowance for the equipment long-term drift, variations with environmental changes, vibration and shock during transportation, overloading, mis-handling, or the capability of any other laboratory to repeat the calibration. Acoustic Testing Services Limited shall not be liable for any loss or damage resulting from the use of the equipment.

4. Calibration Results

Nominal value dB	Measured value dB	IEC 60942 Class 1 Tolerance Limits dB	Conclusion	Expanded Measurement Uncertainty of Reference Microphone B&K 4189 at 1000 Hz dB
94.00	93.8	± 0.25	PASS	0.2
114.00	113.8	± 0.25	PASS	0.2

All calibration points are within manufacturer's specification.



Certificate No.: ATS22-025-CC002

Page 2 of 2

Appendix C. Measurement Photos

Photo C1. Measurement Photo for Travelling Mode



Photo C2. Measurement Photo for Concrete Discharge Mode

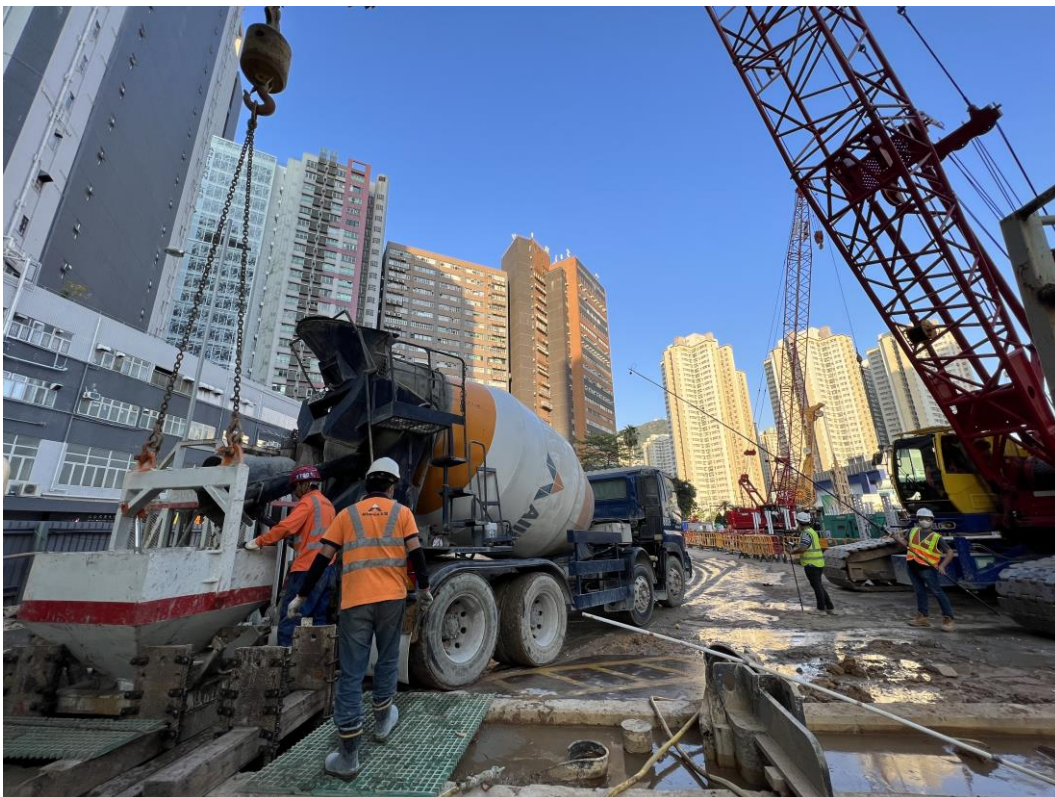

Appendix D. Expanded Measurement Uncertainty

Reproducibility		Instability of Operation & Mounting Conditions	
Standard Deviation, σ_{R0} , dB	3	Standard Deviation, σ_{omc} , dB	0.5
Total Standard Deviation, $\sigma_{tot} = (\sigma_{R0}^2 + \sigma_{omc}^2)^{1/2}$, dB		Expanded Measurement Uncertainty, $U = k \sigma_{tot}$, dB	
3		6.1	

- Notes:
1. $\sigma_{R0} = 3$, for a noise source which emits sound without significant tones.
 2. $\sigma_{omc} = 0.5$, for the sound power which has only a small variation with time and measurement procedure is defined properly, a value of 0.5 dB for σ_{omc} can apply.
 3. $k = 2$, for a normal distribution of measured values, there is 95% confidence that the true value lies within the range $(L_w - U)$ to $(L_w + U)$.
 4. The SWL as stated in this report was measured in worst-case operation. Expanded Measurement Uncertainty, U , is not required to add to the measured SWL.

Contract No. 21/WSD/21

Relocation of Diamond Hill Fresh Water and Salt Water Reservoirs to Caverns

Appendix G - Relevant School Examination Calendar

Our Lady's College School Calendar 2023 – 2024

2023	Cycle	Sun	Mon	Tue	Wed	Thu	Fri	Sat	Date	Events
S E P							1	2	1	School Opening Ceremony 開學禮
	1	3	4 ¹	5 ²	6 ³	7 ⁴	8 ⁵	9	4-11	First Cycle (Special Timetable of First cycle) 首循環週 (首循環週特別時間表)
	1/2	10	11 ⁶	12 ¹	13 ²	14 ³	15 ⁴	16	11	School Opening Mass 開學彌撒
	2/3	17	18 ⁵	19 ⁶	20 ¹	21 ²	22 ³	23	22	S6 Parents' Night 中六家長晚會
	3/4	24	25 ⁴	26 ⁵	27 ⁶	28 ¹	29 ²	+30	30	The day following Mid-Autumn Festival 中秋節翌日
O C T	4	1	+2	3 ³	4 ⁴	5 ⁵	6 ⁶	7	2	The day following National Day 國慶日翌日
	5	8	9 ¹	10 ²	11 [▲]	12 ⁴	13 ⁵	14		
	5/6	15	16 ⁶	17 ¹	18 ²	19 ³	20 ⁴	21	17-31	S6 Pre-Mock Exam 中六模擬畢業試
	6	22	+23	24 ⁵	25 ⁶	26	27	28	23	Chung Yeung Festival 重陽節
		29	30	31					25	Staff Development Day-PM (Special Timetable) 教師發展日-下午 (特別時間表)
N O V					1 ¹	2 ²	3 ³	4	26-31	S1-S5 Term Test 中一至中五測驗日
	7	5	6 ⁴	7 ⁵	8 ⁶	9	10	11	9	Sports Day 陸運會
	7	12	13 ¹	14 ²	15 ³	16 ⁴	17 ⁵	18	10	School Holiday 學校假期
	8	19	20 ⁶	21 [▲]	22 ²	23 ³	24 ⁴	25	18	Parents' Day & PTA AGM 家長日暨家長教師會會員大會
	8/9	26	27	28 ⁵	29 ⁶	30 ¹			25	School Information Day 學校資訊日
D E C	9/10								27	School Holiday 學校假期
	10						1 ²	2		
	10	3	4 ³	5	6	7 ⁴	8 ⁵	9	5	School Picnic 學校旅行
	10/11	10	11 ⁶	12 ¹	13 ²	14 ³	15	16	6	School Holiday 學校假期
	11	17	18 ⁴	19 ⁵	20 ⁶	21	22	23	11	The Day after a District Council Ordinary Election 區議會選舉翌日
		24	+25	+26	27	28	29	30	15	Staff Development Day 教師發展日
	31							21	Christmas Celebration 聖誕慶祝活動	
								22/12-1/1	Christmas and New Year Holidays 聖誕及新年假期	
2024		+1	2	3	4	5	6			
J A N		7	8	9	10	11	12	13	2-12	S1-S5 First Term Exam 中一至中五第一段考
	12	14	15 ¹	16 ²	17 ³	18 ⁴	19 ⁵	20		
	12/13	21	22 ⁶	23 ¹	24 ²	25 ³	26 ⁴	27	15-29	S6 Mock Exam 中六畢業試
	13	28	29 [▲]	30 ⁶	31				31	St. John Bosco Mass & Thanksgiving Day-AM 聖若望鮑思高神父彌撒及感恩日-上午 FMA Joint School Teachers' Day-PM 母佑會聯校教師日-下午
F E B	14					1 ¹	2 ²	3	3	General Parents' Day 家長日
	14	4	5 ³	6 ⁴	7 ⁵	8	9	+10	8-18	Chinese New Year Holidays 農曆新年假期
		11	+12	+13	14	15	16	17		
	14/15	18	19 ⁶	20 ¹	21 [▲]	22 ³	23 ⁴	24		
	25	26 ⁵	27 ⁶	28 ¹	29 ²					

+ Public Holiday 公眾假期

▲ Activity Day(Special Timetable) 活動日(特別時間表)

Catholic & Salesian Liturgical Celebrations 天主教及慈幼大家庭禮儀慶節

Advent 將臨期 3/12-24/12

Christmas 聖誕節 25/12

Lent 四旬期 14/2-28/3

Easter 復活節 31/3

St. John Bosco

St. Mary Mazzarello

Mary Help of Christians (School Feast Day)

FMA Foundation Day

聖若望鮑思高

聖女瑪沙利羅

聖母進教之佑 (校慶日)

母佑會創會日

31/1

13/5

24/5

5/8

2024	Cycle	Sun	Mon	Tue	Wed	Thu	Fri	Sat	Date	Events
M A R	16						1	2	1	S3 Parents' Night 中三家長晚會
	16/17	3	4	5	6	7	8	9		
	17/18	10	11	12	13	14	15	16		
	18	17	18	19	20	21	22	23		
		24	25	26	27	28	+29	+30	25 26/3-7/4	Whole Day Activity Day 整天活動日 Easter Holidays 復活節假期
		31								
A P R			+1	2	3	+4	5	6	4	Ching Ming Festival 清明節
	19	7	8	9	10	11	12	13	9/4-7/5	HKDSE 香港中學文憑考試
	19	14	15	16	17	18	19	20	10 11-16	Staff Development Day-PM (Special Timetable) 教師發展日-下午 (特別時間表) S1-S5 Term Test 中一至中五測驗日
	20	21	22	23	24	25	26	27	23 or 24	S3 TSA (Speaking) 中三全港性系統評估 (說話) (26: Fallback Date 後備日)
	20/21	28	29	30						
M A Y	21				+1	2	3	4	1	Labour Day 勞動節
	21/22	5	6	7	8	9	10	11	6	Staff Development Day 教師發展日
	22	12	13	14	15	16	17	18	15	Birthday of the Buddha 佛誕
	22/23	19	20	21	22	23	24	25	24	Speech Day 畢業禮
	23/24	26	27	28	29	30	31		27 27-31	Mary Help of Christians Mass & School Feast Day 聖母進教之佑瞻禮彌撒及校慶日 Exam Preparation Days (Special Timetable) 考試預備日 (特別時間表)
J U N								1		
		2	3	4	5	6	7	8	3-14	S1-S5 Final Exam 中一至中五年終試
		9	+10	11	12	13	14	15	10	Tuen Ng Festival 端午節
		16	17	18	19	20	21	22	18-19 19-20	Exam Paper Review 核對試卷 S3 TSA (Written) 中三全港性系統評估 (紙筆) (24: Fallback Date 後備日)
		23	24	25	26	27	28	29	24/6-5/7	Post Exam Activities 試後活動
		30								
J U L			+1	2	3	4	5	6	1	HKSAR Establishment Day 香港特別行政區成立紀念日
		7	8	9	10	11	12	13	9	Allocation Results (SSPA) Release 公布派位結果 (中學學位分配)
		14	15	16	17	18	19	20	10 11-12	End of Term Assembly & Distribution of Report Cards 散學禮及派發成績表 Pre-S1 Registration 中一新生註冊
		21	22	23	24	25	26	27	12	S6 Parents' Night 中六家長晚會
		28	29	30	31				15 16 17	Commencement of Summer Vacation 暑假開始 Pre-S1 HK Attainment Test 中一入學前香港學科測驗 HKDSE Results Release 公布香港中學文憑考試成績
A U G						1	2	3		
		4	5	6	7	8	9	10		
		11	12	13	14	15	16	17		
		18	19	20	21	22	23	24		
		25	26	27	28	29	30	31		

